

	Product information 50WQ25-35-7.5(I)	Manufacturer	CNP
		Address	Yuhang District, Hangzhou,
Project Name		Contact	86-571-88637351
		Date	2022/03/09
Station Number		Client Name	DPA
		Client Addr.	
		Contacts	Alireza
		Contact	

Product No.	50WQ25-35-7.5(I)
-------------	------------------

Product picture(Note:the picture may not be the same as the	Series description
	Single channel or double channel impeller.Auto-coupling system on request.

Performance Data	
Rated flow(m ³ /h)	25
Rated head(m)	35
Efficiency(%)	47.7
Rated power(kW)(kW)	5.183
Rate Speed(rpm)	2940
technology	
Pump rotator speed	2940
Nameplate standards	CE
Material	
Impeller	HT200
Pump shaft	20cr13
Rubber code	P
Pump case	HT200
Installation	
Connection Code	F
Maximum Pressure/Temperatu	6bar/40
Flange Standard	DIN
Pressure Class	PN6
Medium	
Medium Temperature	40
Maximum diameter of partic	19.5
Maximum Environment Temper	40
Structure dimension	
Standard	DN
Outlet size	DN50
Motor	
Number of Motor Phase	Three Phase
Protection Class	IP68
Insulation Class	F
Motor Power	7.5
Power Frequency	50HZ
Rated Voltage (V)	380V
Rated Current (A)	14.3

	Product information 50WQ25-35-7.5(I)	Manufacturer	CNP
		Address	Yuhang District, Hangzhou,
		Contact	86-571-88637351
		Date	2022/03/09
Project Name		Client Name	DPA
		Client Addr.	
Station Number		Contacts	Alireza
		Contact	

Starting mode direct boot

Seal

Mechanical Seal H-30

Others

Weight (kg) 92



	Performance Curve 50WQ25-35-7.5(I)	Manufacturer	CNP
		Address	Yuhang District, Hangzhou,
Project Name		Contact	86-571-88637351
		Date	2022/03/09
Station Number		Client Name	DPA
		Client Addr.	
		Contacts	Alireza
		Contact	

Medium Name Clear Water , Temperature 20°C, Density 1000kg/m³, Viscosity 1mm²/s, (ISO99062012 Grande 3B)

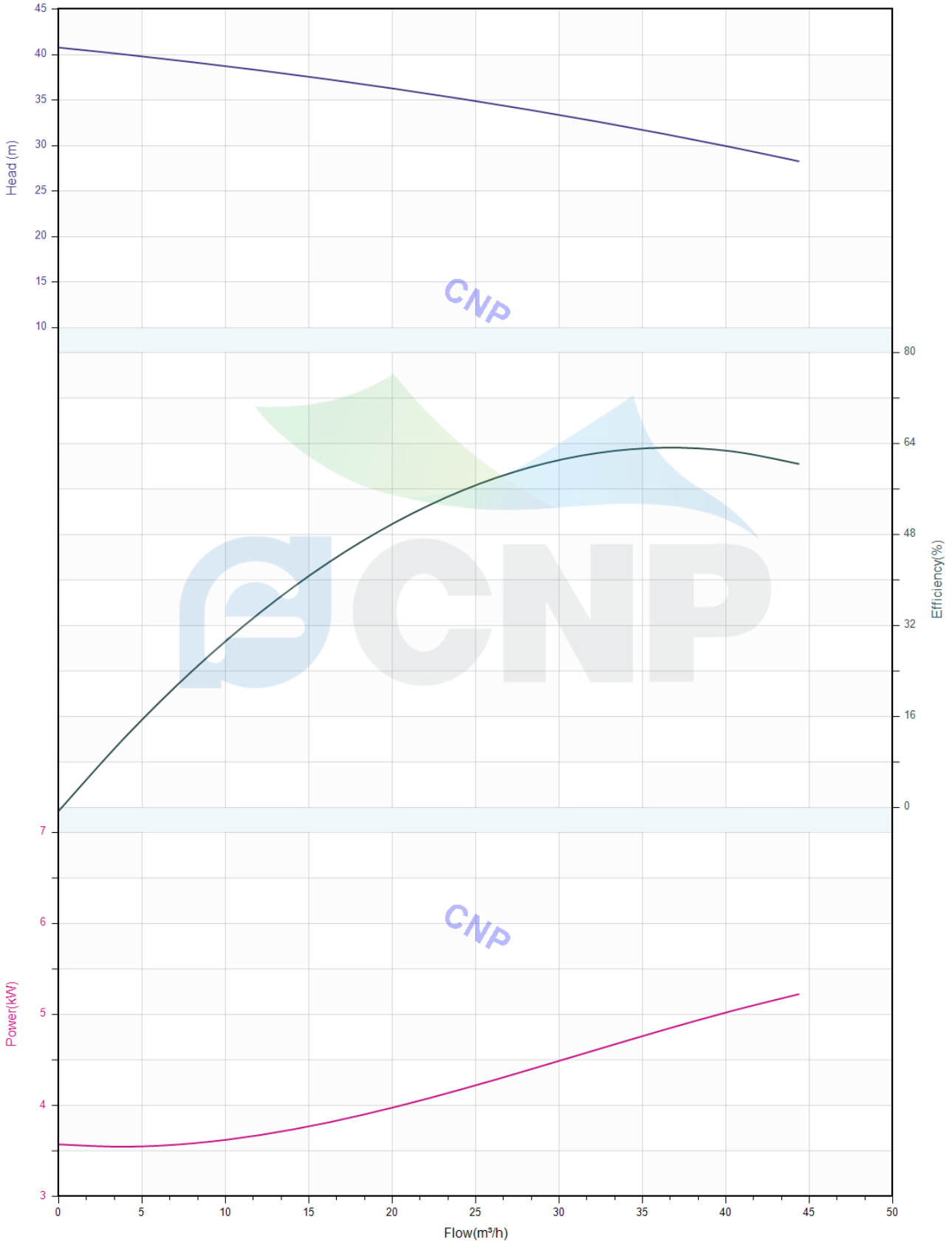



Pump technical parameters 50WQ25-35-7.5(I)

Manufacturer	CNP
Address	Yuhang District, Hangzhou,
Contact	86-571-88637351
Date	2022/03/09
Client Name	DPA
Client Addr.	
Contacts	Alireza
Contact	

Rated parameters

Pump model	50WQ25-35-7.5(I)
Product No.	50WQ25-35-7.5(I)
Rated flow(m ³ /h)	25
Rated pressure(m)	35
Rated efficiency(%)	47.7
Power(kW)	5.183
Speed(rpm)	2940

Medium

Medium Name	Clear Water
Working temperature(°C)	20
Medium density(kg/m ³)	1000
Viscosity(mm ² /s)	1

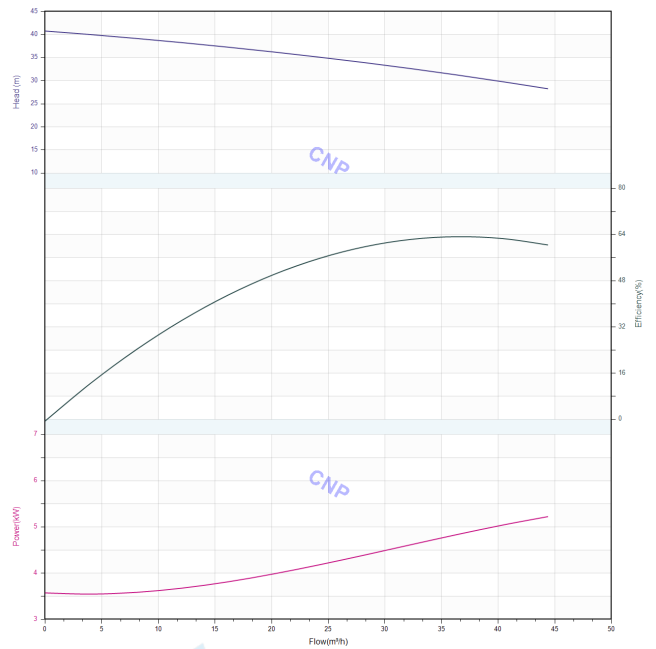



Structure picture
50WQ25-35-7.5(I)

Manufacturer	CNP
Address	Yuhang District, Hangzhou,
Contact	86-571-88637351
Date	2022/03/09
Client Name	DPA
Client Addr.	
Contacts	Alireza
Contact	

Project Name

Station Number

CNP Nanfang Zhongjin Environment Co., Ltd.

SECTIONAL DRAWING		No.	No.
TYPE	submersible sewage pump	MODEL	WQ-5.5/7.5KW

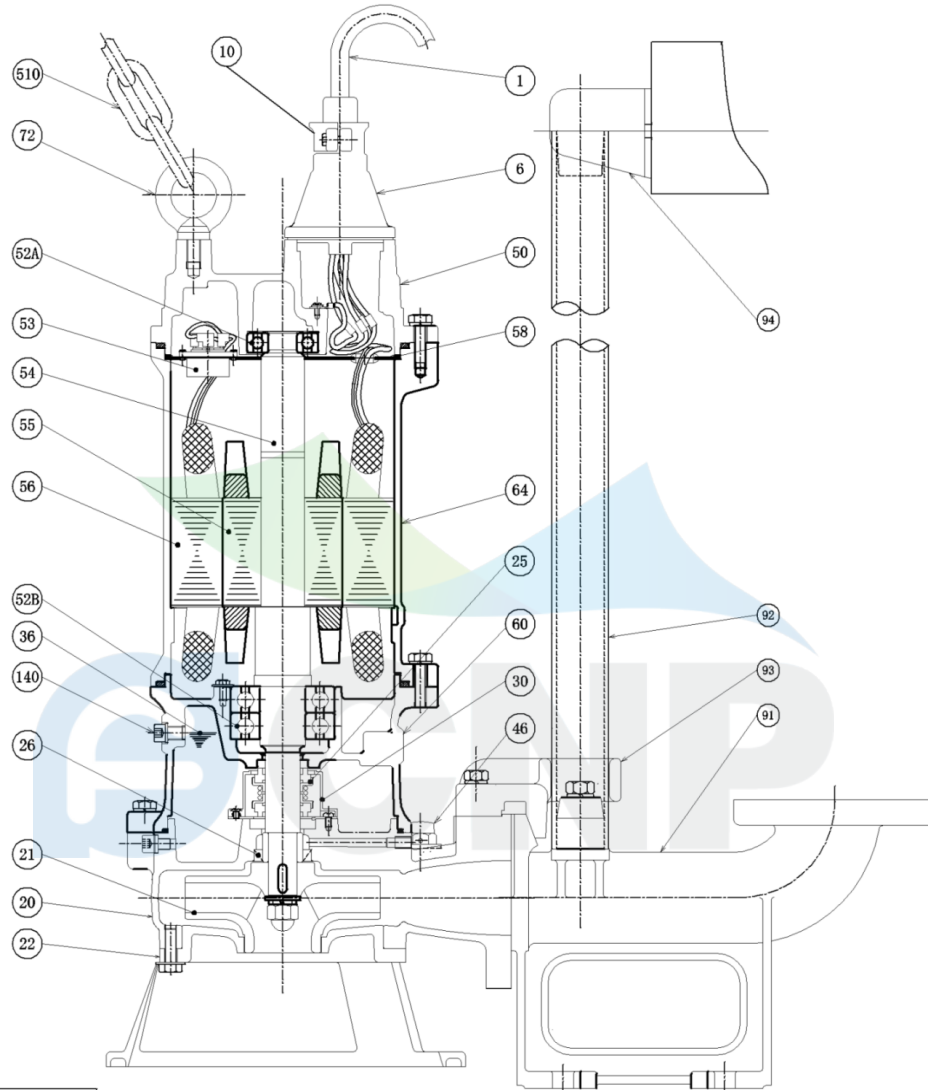

order specifications	
----------------------	--

No.	names of parts	number	material	No.	names of parts	number	material
1	cable	1	YZW	20	casing	1	HT200
6	cable sleeve	1	HT200	21	impeller	1	HT200
50	top cover	1	HT200	26	framework oil seal	1	NBRI-2
58	cable transit board	1	Q235	140	oil filler plug	2	SUS304
64	base	1	HT200	36	machine oil 32#		
25	mechanical seal	1	Carbon/SIC	52B	lower bearing	2	
60	lower cover	1	HT200	56	stator	1	
30	oil lift	1		55	rotor	1	
46	Air release bolt	1		54	shaft	1	
94	guiding	1	HT200	53	thermal protector	1	
92	pipe	1	SUS304(unaffiliated)	52A	upper bearing	1	
93	guide hook	1	HT200	72	eye bolt	2	45#(forging galvanized)
91	water outlet base	1	HT200	510	lift chain	1	SUS304
22	water inlet cover	1	HT200	10	Cable lockblock	2	HT200

Nanfang Zhongjin Environment CO.,LTD.

unit : mm



Installation picture 50WQ25-35-7.5(I)

Manufacturer	CNP
Address	Yuhang District, Hangzhou,
Contact	86-571-88637351
Date	2022/03/09
Client Name	DPA
Client Addr.	
Contacts	Alireza
Contact	

Project Name

Station Number

CNP Nanfang Zhongjin Environment Co., Ltd.

DIMENSION DRAWING		No.	No.												
TYPE submersible sewage pump		MODEL	50WQ25-35-7.5												
MODEL	d	A	A1	A2	A3	A4	A5	B	B1	D	D1	W1	W2	H	Body weight
50WQ25-35-7.5	50	414	474	145	205	272	285	221	221	290	145	450	153	790	84.0kg

diameter	elbow weight	bend weight
50	1.5kg	3.5kg

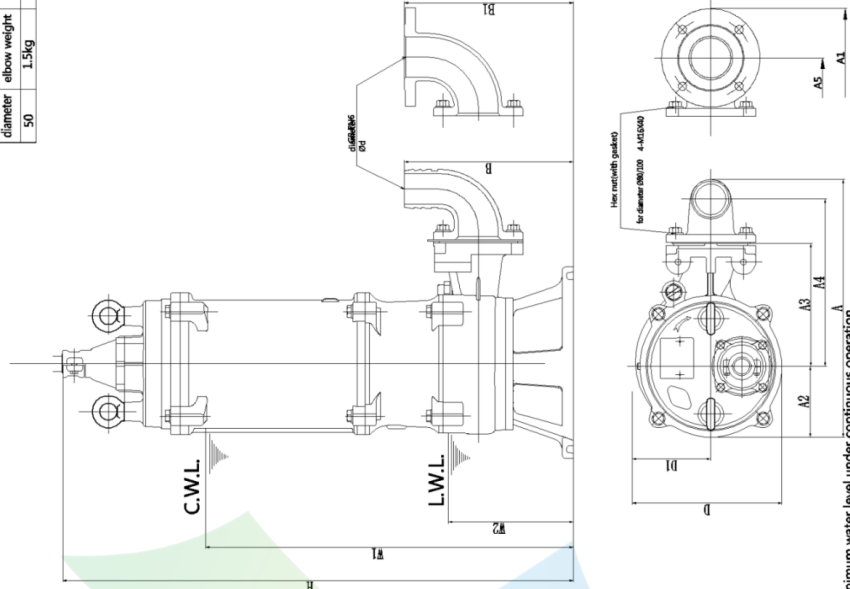

C.W.L.: minimum water level under continuous operation
L.W.L.: minimum water level under possible operation

unit : mm

Nanfang Zhongjin Environment CO.,LTD.

CNP Nanfang Zhongjin Environment Co., Ltd.

DIMENSION DRAWING		No.	No.																	
TYPE submersible sewage pump		MODEL	50WQ25-35-7.5																	
MODEL	A	A1	A2	A3	A4	D	D1	W1	W2	H	H1	H2	Body weight							
50WQ25-35-7.5	145	310	175	245	260	290	145	504	207	844	1374	54	84kg							
Outer diameter	T1	T2	T3	T4	T5	T6	T7	T8	T9	T10	K1	K2	Consulting weight							
50WQ25-35-7.5	50	230	185	70	50	160	200	117	246	35	25	120	120	40	110	10	250	202.5	15	13.5kg

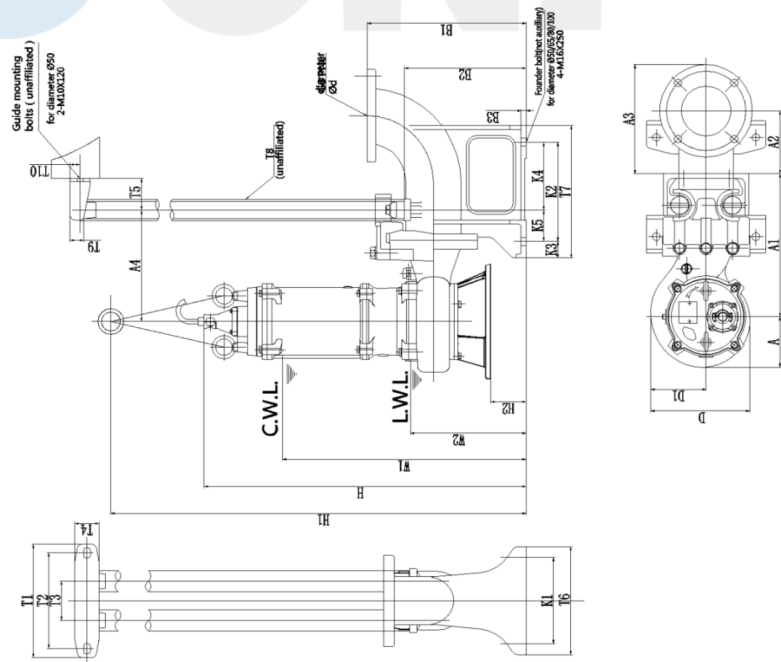

C.W.L.: minimum water level under continuous operation
L.W.L.: minimum water level under possible operation

unit : mm

Nanfang Zhongjin Environment CO.,LTD.