	<b>Product Information</b> <b>300WQ700-8-22(I)</b>	Manufacturer	CNP
		Address	Yuhang District, Hangzhou, Zhejiang,
<b>Project Name</b>		Contact	86-571-88637351
		Date	2022/03/09
<b>Item NO</b>		Client Name	DPA
		Client Addr.	
		Contacts	Alireza
		Contact	

Part NO.	300WQ700-8-22
----------	---------------

Product Picture	Note
	<p>The sewage submersible pump is composed of two parts: the motor and the pump.</p> <p>The two are separated by an oil chamber and a mechanical seal assembly.</p> <p>Divided into fixed automatic coupling installation and mobile installation</p>

<b>technology</b>	
Pump rotator speed	983
Nameplate standards	CE
<b>Material</b>	
Impeller	HT200
Pump shaft	20cr13
Rubber code	P
Pump case	HT200
<b>Installation</b>	
Connection Code	F
Maximum Pressure/Temperatu	6bar/40
Flange Standard	DIN
Pressure Class	PN6
<b>Medium</b>	
Medium Temperature	40
Maximum diameter of partic	66
Maximum Environment Temper	40
<b>Structure dimension</b>	
Standard caliber	DN
Outlet Diameter	DN300
<b>Motor</b>	
Number of Motor Phase	Three Phase
Protection Class	IP68
Insulation Class	F
Motor Power	22
Power Frequency	50HZ
Rated Voltage (V)	380V
Rated Current (A)	45
Starting mode	direct boot
<b>Seal</b>	
Mechanical Seal	H-60
<b>Others</b>	
Weight (kg)	658



### Performance Curve 300WQ700-8-22(I)

Manufacturer	CNP
Address	Yuhang District, Hangzhou, Zhejiang,
Contact	86-571-88637351
Date	2022/03/09
Client Name	DPA
Client Addr.	
Contacts	Alireza
Contact	

Project Name

Item NO

The hydraulic performance curve have been tested with Clean Water at 20°C, density 1000kg/m<sup>3</sup>, and at 1bar atmospheric pressure. ISO99062012 Grade 3B

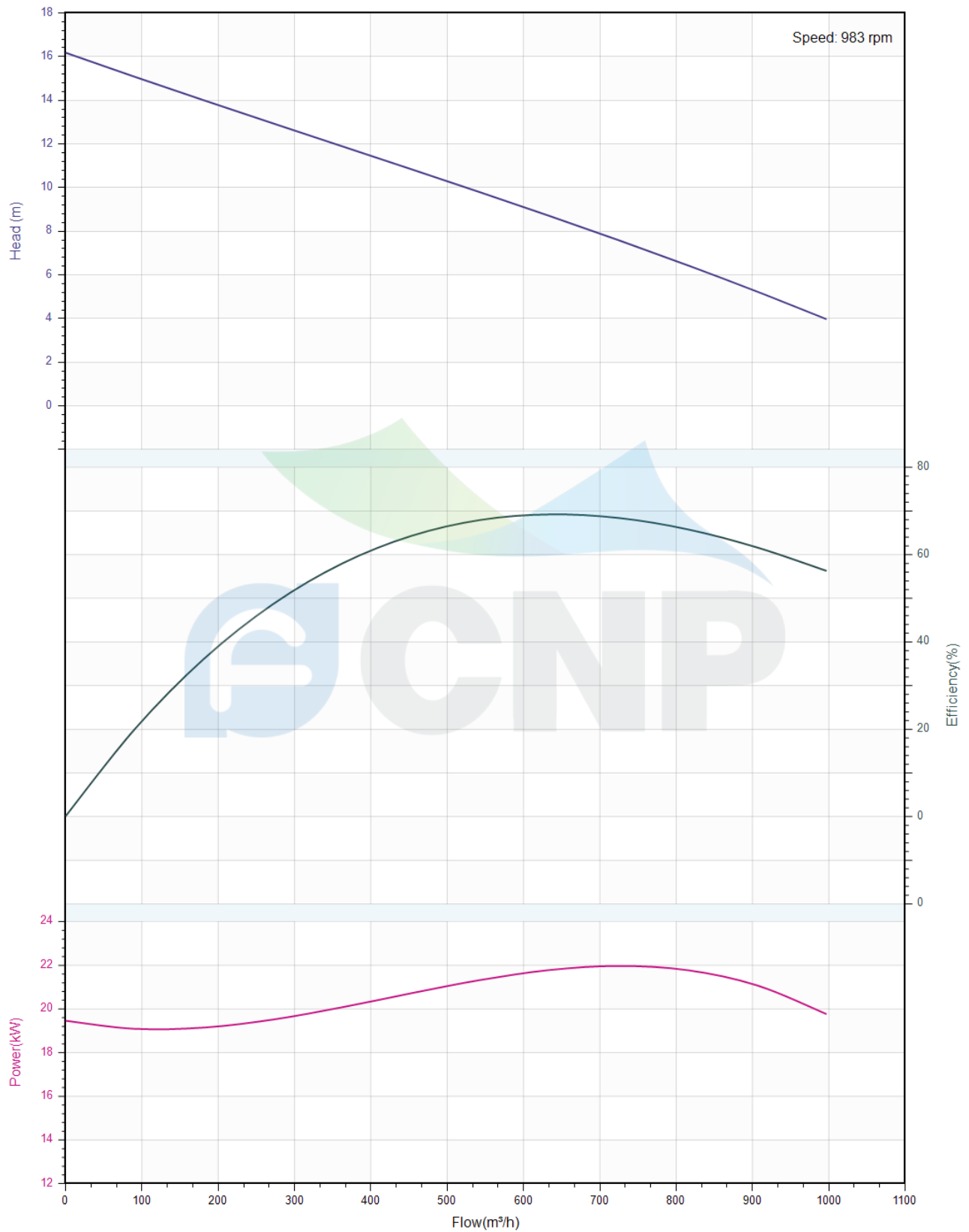



## Pump Technical Parameters 300WQ700-8-22(I)

Manufacturer	CNP
Address	Yuhang District, Hangzhou, Zhejiang,
Contact	86-571-88637351
Date	2022/03/09
Client Name	DPA
Client Addr.	
Contacts	Alireza
Contact	

### Rated parameters

Pump model	300WQ700-8-22(I)
Part NO.	300WQ700-8-22
Rated flow (m <sup>3</sup> /h)	700
Rated head (m)	8
Rated efficiency (%)	70.5
Power (kW)	21.65
NPSHr (m)	2
Speed (rpm)	983

### Medium

Pumped medium	Clean Water
Working temperature (°C)	20
Medium density (kg/m <sup>3</sup> )	1000
Viscosity (mm <sup>2</sup> /s)	1

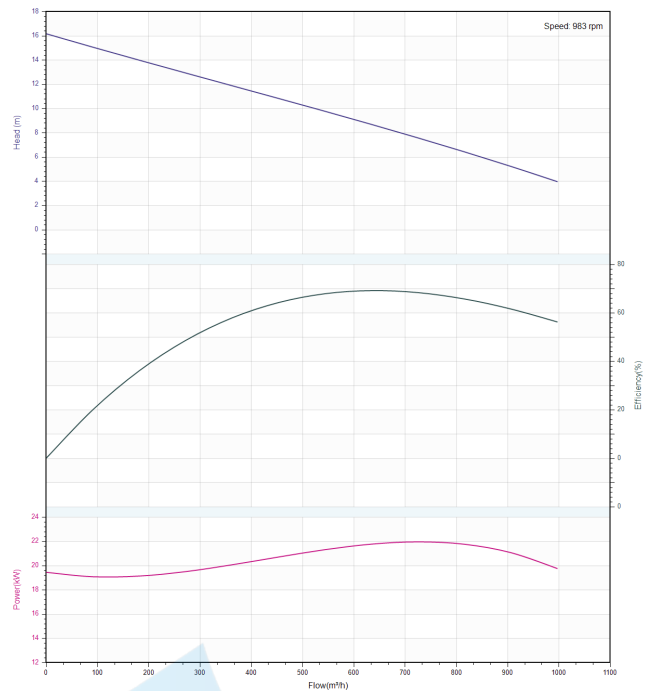

	<b>Structure picture</b> <b>300WQ700-8-22(I)</b>	Manufacturer	CNP
		Address	Yuhang District, Hangzhou, Zhejiang,
		Contact	86-571-88637351
		Date	2022/03/09
Project Name		Client Name	DPA
Item NO		Client Addr.	
		Contacts	Alireza
		Contact	

 Nanfang Zhongjin Environment Co., Ltd.

	SECTIONAL DRAWING	No.	No.
TYPE	submersible sewage pump	MODEL	18. 5/22KW

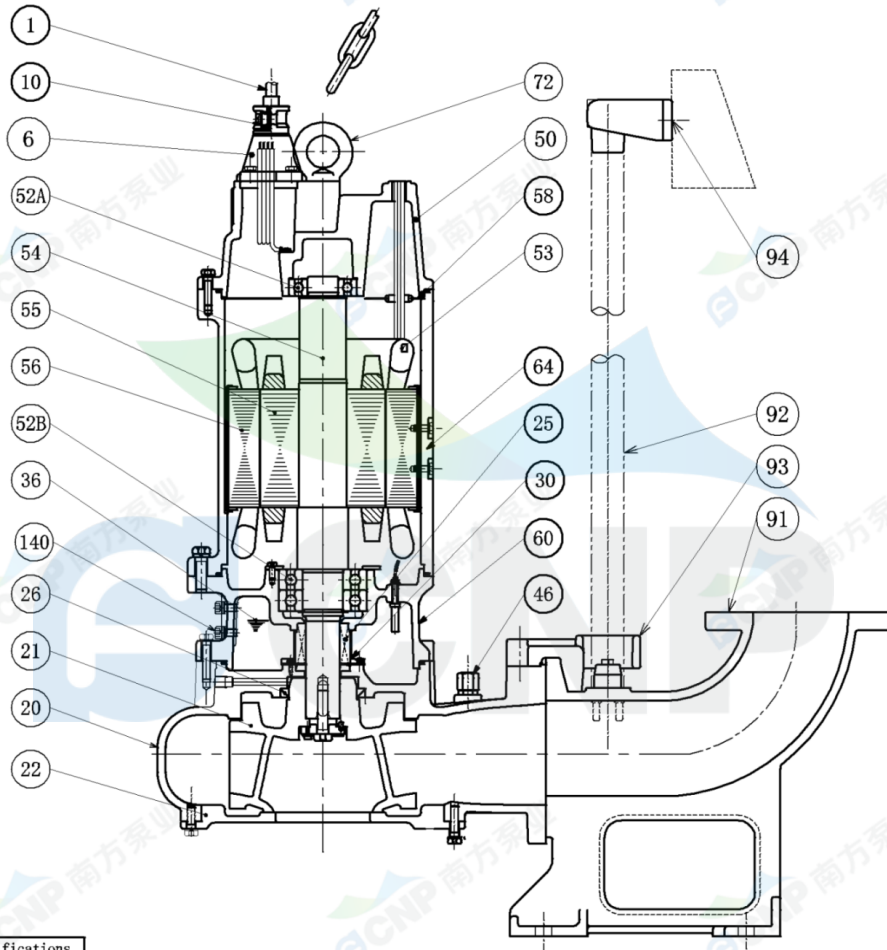

order specifications

No.	names of parts	number	material	No.	names of parts	number	material
1	cable	1	YZW	20	casing	1	HT200
6	cable sleeve	1	HT200	21	impeller	1	HT200
50	top cover	1	HT200	26	framework oil seal	1	NBRI-2
58	cable transit board	1	Q235	140	oil filler plug	2	SUS304
64	base	1	HT200	36	machine oil 32#		
25	mechanical seal	1	Carbon/SiC	52B	lower bearing	2	
60	lower cover	1	HT200	56	stator	1	
30	oil lift	1		55	rotor	1	
46	Air release bolt	1		54	shaft	1	
94	guiding	1	HT200	53	Mini-thermalprotector	1	
92	pipe	1	SUS304(unaffiliated)	52A	upper bearing	1	
93	guide hook	1	HT200	72	eye bolt	2	45#(forging galvanized)
91	water outlet base	1	HT200	95	lift chain	1	SUS304
22	water inlet cover	1	HT200	10	电缆线锁紧块	2	HT200

Nanfang Zhongjin Environment CO.,LTD.

unit: mm



### Installation picture 300WQ700-8-22(I)

Manufacturer	CNP
Address	Yuhang District, Hangzhou, Zhejiang,
Contact	86-571-88637351
Date	2022/03/09
Client Name	DPA
Client Addr.	
Contacts	Alireza
Contact	

Project Name

Item NO

CNP 中金环境

安装外形尺寸 DIMENSION DRAWING	No.	No.
污水污物潜水泵	MODEL 300WQ700-8-22-6	
型号	型号	型号

300WQ700-8-22-6	A	A1	A2	A3	A4	A5	B	B1	D	D1	D2	H	H1	H2	H3	总重量
300	1450	850	1150	850	450	184	1032	832	180	280	1200	541	1883	1883	1883	33.5kg
300	1450	850	1150	850	450	184	1032	832	180	280	1200	541	1883	1883	33.5kg	

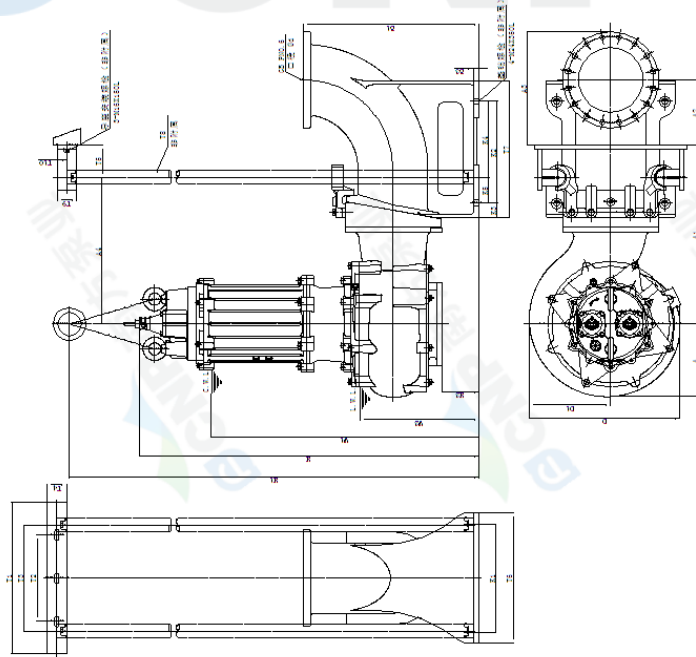

C.W.L.: 潜水排污泵外形图  
L.W.L.: 潜水排污泵外形图

南方中金环境股份有限公司 Nanfang Zhongjin Environment CO., LTD. unit: mm

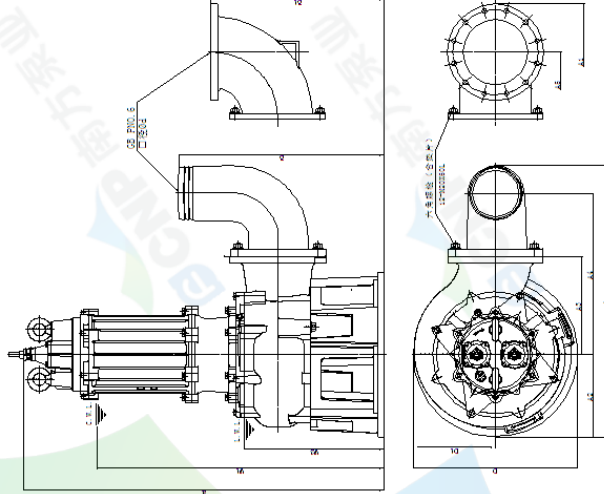

C.W.L.: 潜水排污泵外形图  
L.W.L.: 潜水排污泵外形图

南方中金环境股份有限公司 Nanfang Zhongjin Environment CO., LTD. unit: mm