	<b>Product Information</b> <b>200WQ400-25-45(I)</b>	Manufacturer	CNP
		Address	Yuhang District, Hangzhou, Zhejiang,
		Contact	86-571-88637351
		Date	2022/03/09
<b>Project Name</b>		Client Name	DPA
		Client Addr.	
<b>Item NO</b>		Contacts	Alireza
		Contact	

Part NO.	200WQ400-25-45(I)
----------	-------------------

Product Picture	Note
	<p>The sewage submersible pump is composed of two parts: the motor and the pump.</p> <p>The two are separated by an oil chamber and a mechanical seal assembly.</p> <p>Divided into fixed automatic coupling installation and mobile installation</p>

<b>technology</b>	
Pump rotator speed	1470
Nameplate standards	CE
<b>Material</b>	
Impeller	HT200
Pump shaft	20cr13
Rubber code	P
Pump case	HT200
<b>Installation</b>	
Connection Code	F
Maximum Pressure/Temperatu	6bar/40
Flange Standard	DIN
Pressure Class	PN6
<b>Medium</b>	
Medium Temperature	40
Maximum diameter of partic	40
Maximum Environment Temper	40
<b>Structure dimension</b>	
Standard caliber	DN
Outlet Diameter	DN200
<b>Motor</b>	
Number of Motor Phase	Three Phase
Protection Class	IP68
Insulation Class	F
Motor Power	45
Power Frequency	50HZ
Rated Voltage (V)	380V
Rated Current (A)	87
Starting mode	Star delta boot
<b>Seal</b>	
Mechanical Seal	H-60
<b>Others</b>	
Weight (kg)	650



# Performance Curve 200WQ400-25-45(I)

Manufacturer	CNP
Address	Yuhang District, Hangzhou, Zhejiang,
Contact	86-571-88637351
Date	2022/03/09
Client Name	DPA
Client Addr.	
Contacts	Alireza
Contact	

Project Name	
Item NO	

The hydraulic performance curve have been tested with Clean Water at 20°C, density 1000kg/m<sup>3</sup>, and at 1bar atmospheric pressure. ISO99062012 Grade 3B

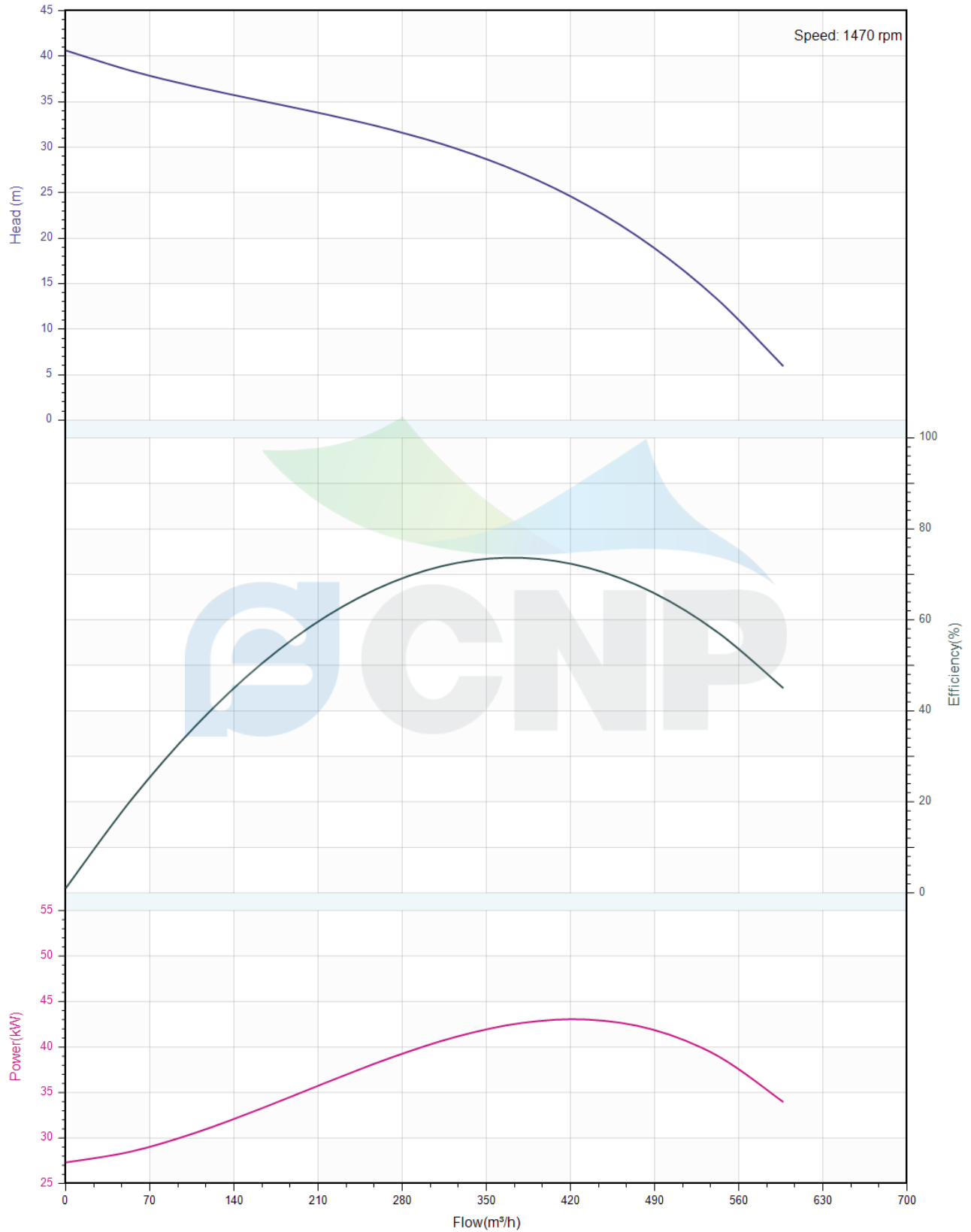



## Pump Technical Parameters 200WQ400-25-45(I)

Manufacturer	CNP
Address	Yuhang District, Hangzhou, Zhejiang,
Contact	86-571-88637351
Date	2022/03/09
Client Name	DPA
Client Addr.	
Contacts	Alireza
Contact	

### Rated parameters

Pump model	200WQ400-25-45(I)
Part NO.	200WQ400-25-45(I)
Rated flow (m <sup>3</sup> /h)	400
Rated head (m)	25
Rated efficiency (%)	64.7
Power (kW)	42.1
Speed (rpm)	1470

### Medium

Pumped medium	Clean Water
Working temperature (°C)	20
Medium density (kg/m <sup>3</sup> )	1000
Viscosity (mm <sup>2</sup> /s)	1

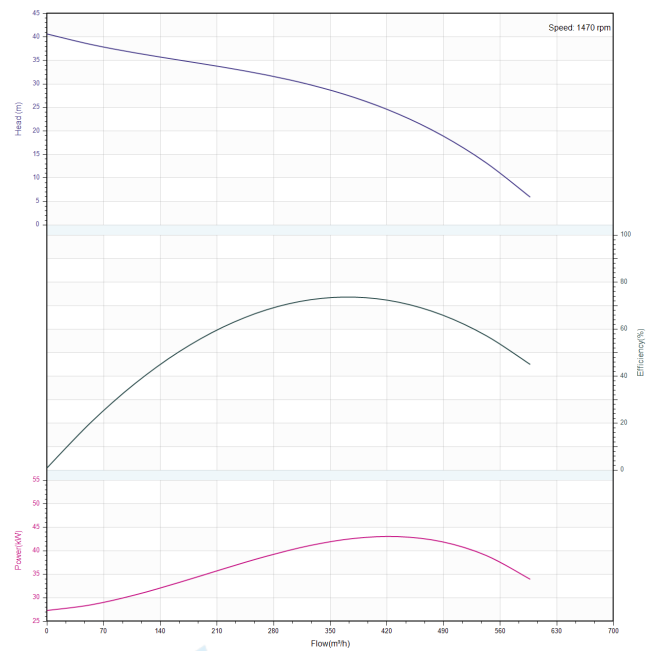

	<b>Structure picture</b> <b>200WQ400-25-45(I)</b>	Manufacturer	CNP
		Address	Yuhang District, Hangzhou, Zhejiang,
Project Name		Contact	86-571-88637351
		Date	2022/03/09
Item NO		Client Name	DPA
		Client Addr.	
		Contacts	Alireza
		Contact	

 Nanfang Zhongjin Environment Co., Ltd.

	SECTIONAL DRAWING	No.	No.
TYPE	submersible sewage pump	MODEL	45KW

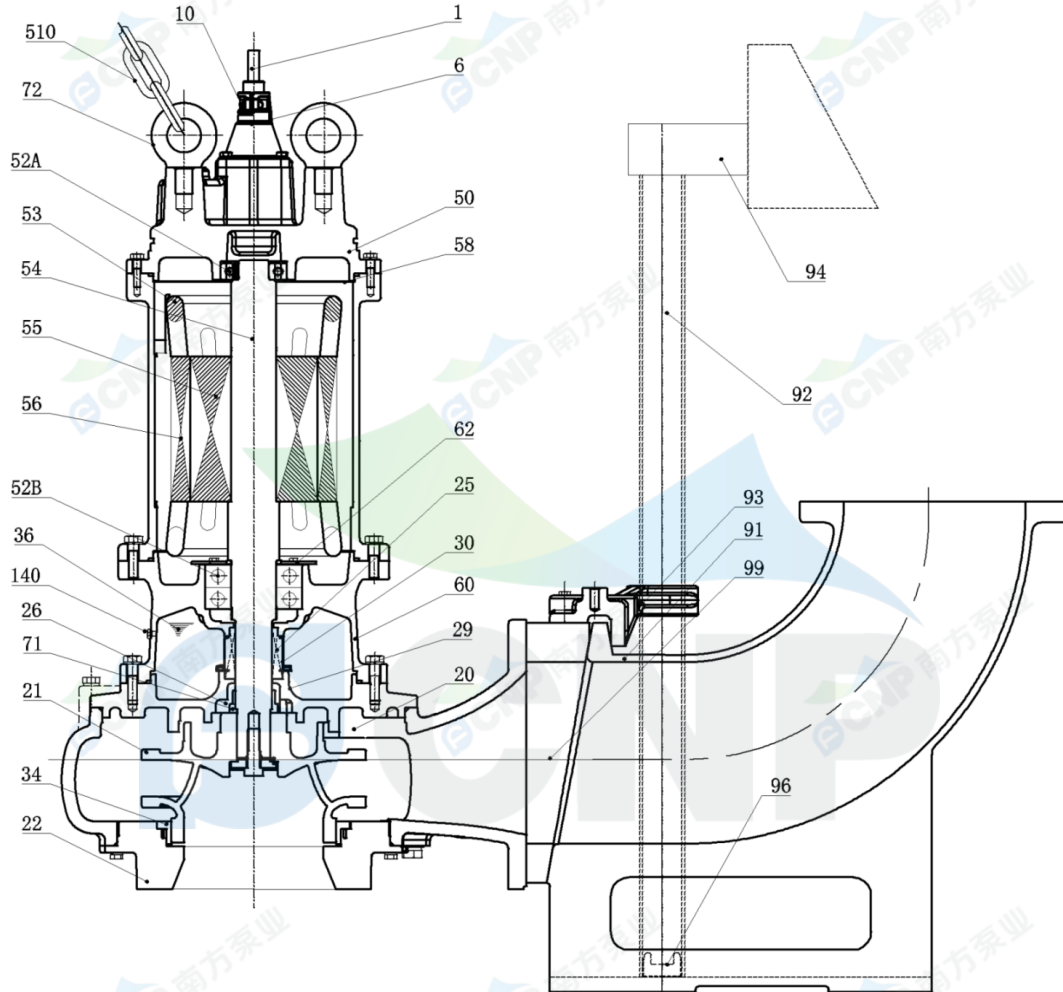

order specifications
----------------------

No.	names of parts	number	material	No.	names of parts	number	material
1	cable	2	YCW	54	shaft	1	2Cr13+45#
6	cable sleeve	2	HT200	55	rotor	1	
50	top cover	1	HT200	56	stator	1	
58	cable transit board	1	Q235	52B	lower bearing	2	
64	base	1	HT200	36	machine oil 32#		
62	Bearing cover	1	HT200	26	framework oil seal	3	NBRI-2
25	mechanical seal	1	Carbon/SiC	140	oil filler plug	2	SUS304
30	oil lift	1		71	Shaft sleeve	2	1Cr13
60	lower cover	1	HT200	21	impeller	1	HT200
29	Casingtop cover	1	HT200	22	water inlet cover	1	HT200
20	casing	1	HT200	34	Neck ring	2	HT200
510	lift chain	1	SUS304	94	guiding	1	Q235Steel plate
10	Cable lockblock	2	HT200	92	pipe	2	SUS304(unaffiliated)
72	eye bolt	2	45#(forging galvanized)	93	guide hook	1	QT600
52A	upper bearing	1		91	Discharge base	1	HT200
53	Mini-thermalprotector	1		99	Flange for coupling device	1	HT200
				96	Guiding fixing stopper	2	HT150

Nanfang Zhongjin Environment CO.,LTD.

unit: mm

