	Product Information 200WQ400-15-30(I)	Manufacturer	CNP
		Address	Yuhang District, Hangzhou, Zhejiang,
Project Name		Contact	86-571-88637351
		Date	2022/03/09
		Client Name	DPA
Item NO		Client Addr.	
		Contacts	Alireza
		Contact	

Part NO.	200WQ400-15-30(I)
----------	-------------------

Product Picture	Note
	<p>The sewage submersible pump is composed of two parts: the motor and the pump.</p> <p>The two are separated by an oil chamber and a mechanical seal assembly.</p> <p>Divided into fixed automatic coupling installation and mobile installation</p>

technology	
Pump rotator speed	1450
Nameplate standards	CE
Material	
Impeller	HT200
Pump shaft	20cr13
Rubber code	P
Pump case	HT200
Installation	
Connection Code	F
Maximum Pressure/Temperatur	6bar/40
Flange Standard	DIN
Pressure Class	PN6
Medium	
Medium Temperature	40
Maximum diameter of partic	60
Maximum Environment Temper	40
Structure dimension	
Standard caliber	DN
Outlet Diameter	DN200
Motor	
Number of Motor Phase	Three Phase
Protection Class	IP68
Insulation Class	F
Motor Power	30
Power Frequency	50HZ
Rated Voltage (V)	380V
Rated Current (A)	54.7
Starting mode	direct boot
Seal	
Mechanical Seal	H-60
Others	
Weight (kg)	685



Performance Curve 200WQ400-15-30(I)

Manufacturer	CNP
Address	Yuhang District, Hangzhou, Zhejiang,
Contact	86-571-88637351
Date	2022/03/09
Client Name	DPA
Client Addr.	
Contacts	Alireza
Contact	

Project Name

Item NO

The hydraulic performance curve have been tested with Clean Water at 20°C, density 1000kg/m³, and at 1bar atmospheric pressure. ISO99062012 Grade 3B

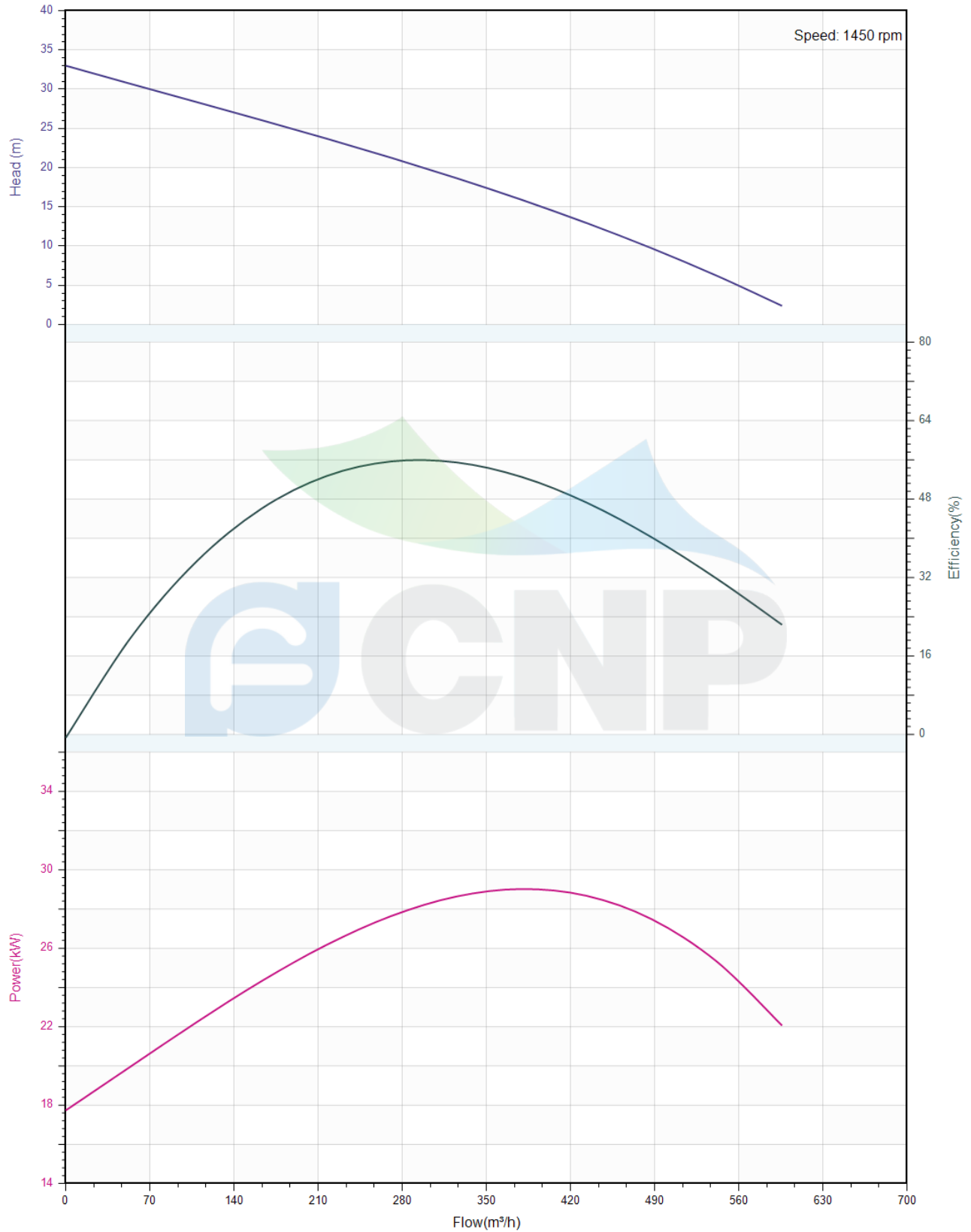



Pump Technical Parameters 200WQ400-15-30(I)

Manufacturer	CNP
Address	Yuhang District, Hangzhou, Zhejiang,
Contact	86-571-88637351
Date	2022/03/09
Client Name	DPA
Client Addr.	
Contacts	Alireza
Contact	

Rated parameters

Pump model	200WQ400-15-30(I)
Part NO.	200WQ400-15-30(I)
Rated flow (m ³ /h)	400
Rated head (m)	15
Rated efficiency (%)	61.2
Power (kW)	27.072
Speed (rpm)	1450

Medium

Pumped medium	Clean Water
Working temperature (°C)	20
Medium density (kg/m ³)	1000
Viscosity (mm ² /s)	1

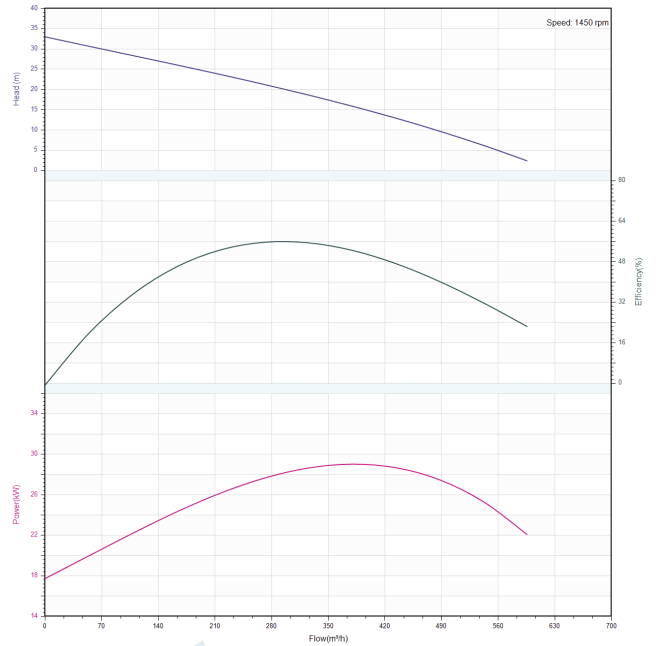

	Structure picture 200WQ400-15-30(I)	Manufacturer	CNP
		Address	Yuhang District, Hangzhou, Zhejiang,
Project Name		Contact	86-571-88637351
		Date	2022/03/09
Item NO		Client Name	DPA
		Client Addr.	
		Contacts	Alireza
		Contact	

CNP Nanfang Zhongjin Environment Co., Ltd.

	SECTIONAL DRAWING	No.	No.
TYPE	submersible sewage pump	MODEL	30/37KW

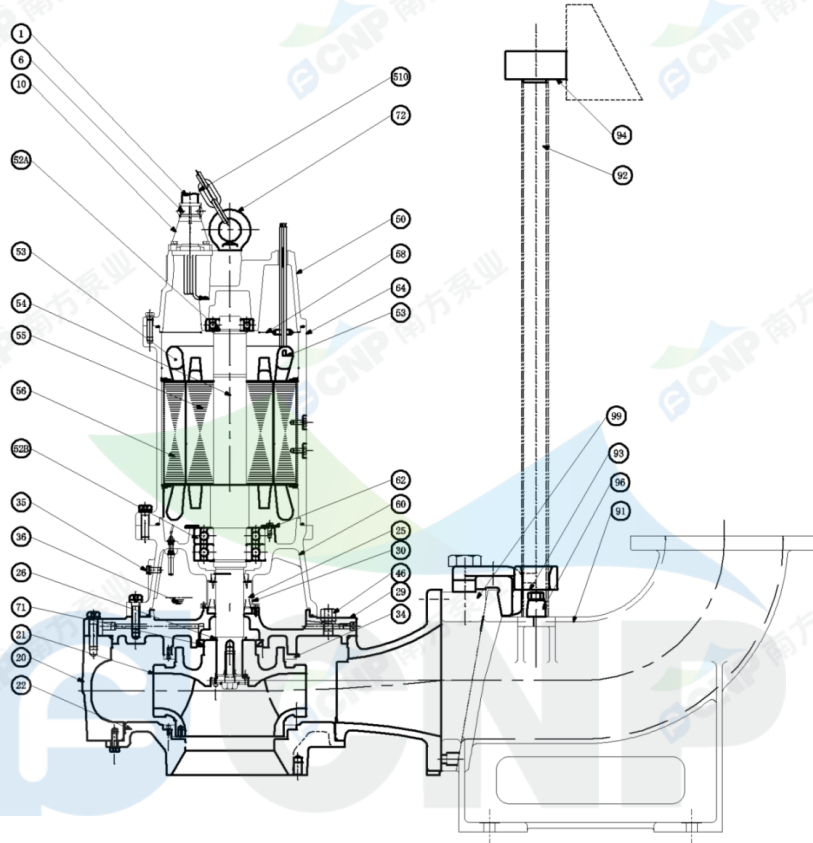

order specifications

No.	names of parts	number	material	No.	names of parts	number	material
1	cable	2	YCW	54	shaft	1	
6	cable sleeve	2	HT200	55	rotor	1	
50	top cover	1	HT200	56	stator	1	
58	cable transit board	1	Q235	52B	lower bearing	2	
64	base	1	HT200	36	machine oil 32#		
62	Bearing cover	1	HT200	26	framework oil seal	3	NBRI-2
25	mechanical seal	1	Carbon/SiC	35	oil filler plug	2	SUS304
30	oil lift	1		71	Shaft sleeve	2	1Cr13
60	lower cover	1	HT200	21	impeller	1	HT200
29	Casingtop cover	1	HT200	22	water inlet cover	1	HT200
20	casing	1	HT200	34	Neck ring	2	HT200
510	lift chain	1	SUS304	94	guiding	1	QT400
10	Cable lockblock	2	HT200	92	pipe	2	SUS304(unaffiliated)
72	eye bolt	2	45#(forging galvanized)	93	guide hook	1	QT500
52A	upper bearing	1		91	Discharge base	1	HT200
53	Mini-thermalprotector	1		99	Flange for coupling device	1	HT200
				96	Guiding fixing stopper	2	HT200

Nanfang Zhongjin Environment CO.,LTD.

unit: mm



Installation picture

200WQ400-15-30(I)

Manufacturer	CNP
Address	Yuhang District, Hangzhou, Zhejiang,
Contact	86-571-88637351
Date	2022/03/09
Client Name	DPA
Client Addr.	
Contacts	Alireza
Contact	

Project Name

Item NO

CNP Nanfang Zhongjin Environment Co., Ltd.

DIMENSION DRAWING		No.	No.
TYPE submersible sewage pump		MODEL 200WQ400-15-30	

MODEL	d	A	A1	A2	A3	A4	B	B1	D	D1	W1	W2	H	Body weight
WQ400-15-30	200	1146	1190	362	450	684	663	785	724	362	1220	560	1690	720kg

dimension	weight
diameter	200
elbow weight	28.5kg
bend weight	33kg

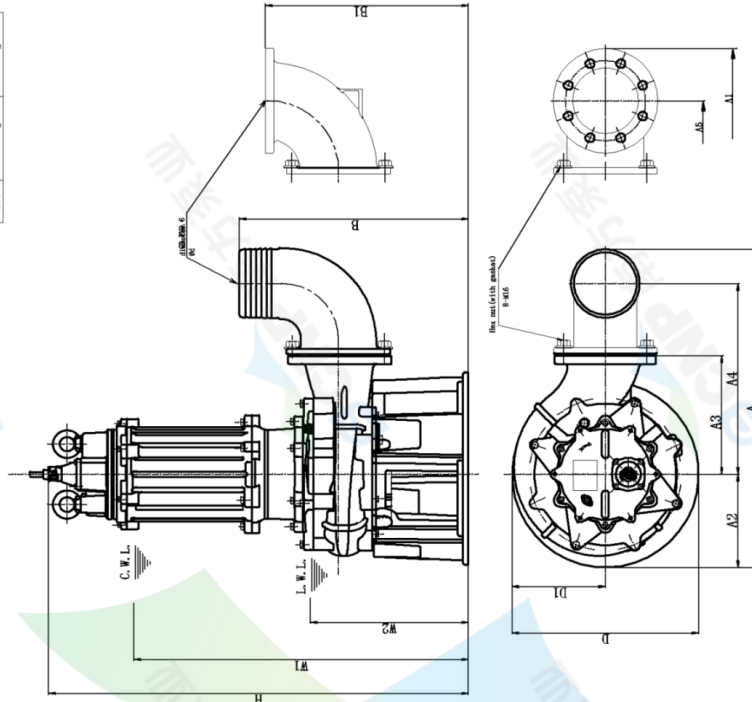

C.W.L.: minimum water level under continuous operation
L.W.L.: minimum water level under possible operation

Nanfng Zhongjin Environment CO., LTD. unit: mm

CNP Nanfang Zhongjin Environment Co., Ltd.

DIMENSION DRAWING		No.	No.
TYPE submersible sewage pump		MODEL 200WQ400-15-30	

MODEL	A	A1	A2	A3	A4	B	B1	W1	W2	H	H1	H2	Body weight
200WQ400-15-30	265	742	229	394	642	611	518	1070	420	1427	2427	126	720kg

Outlet diameter	d	T1	T2	T3	T4	T5	T6	T7	T8	T9	T10	K1	K2	K3	K4	K5	K6	Counting weight
200WQ400-15-30	200	380	280	60	100	400	450	1.5" (50x3)	60	30	300	350	50	250	100	550	15	86kg

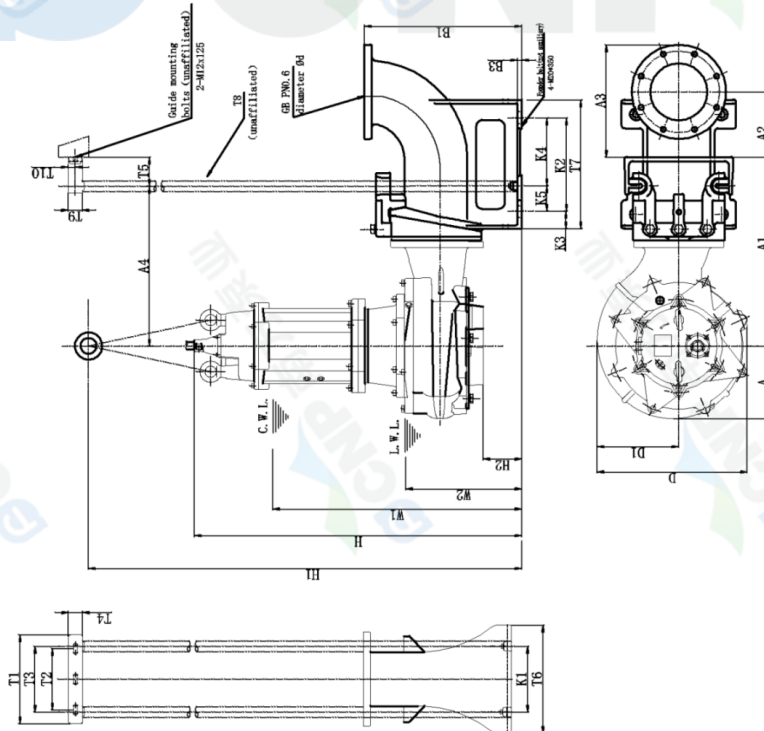

C.W.L.: minimum water level under continuous operation
L.W.L.: minimum water level under possible operation

Nanfng Zhongjin Environment CO., LTD. unit: mm