	<b>Product Information</b> <b>150WQ140-14-11W(I)</b>	Manufacturer	CNP
		Address	Yuhang District, Hangzhou, Zhejiang,
<b>Project Name</b>		Contact	86-571-88637351
		Date	2022/03/09
		Client Name	DPA
<b>Item NO</b>		Client Addr.	
		Contacts	Alireza
		Contact	

Part NO.	150WQ140-14-11W(I)
----------	--------------------

Product Picture	Note
	<p>The sewage submersible pump is composed of two parts: the motor and the pump.</p> <p>The two are separated by an oil chamber and a mechanical seal assembly.</p> <p>Divided into fixed automatic coupling installation and mobile installation</p>

<b>technology</b>	
Pump rotator speed	1440
Nameplate standards	CE
<b>Material</b>	
Impeller	HT200
Pump shaft	20cr13
Rubber code	P
Pump case	HT200
<b>Installation</b>	
Connection Code	F
Maximum Pressure/Temperatur	6bar/40
Flange Standard	DIN
Pressure Class	PN6
<b>Medium</b>	
Medium Temperature	40
Maximum diameter of partic	52
Maximum Environment Temper	40
<b>Structure dimension</b>	
Standard caliber	DN
Outlet Diameter	DN150
<b>Motor</b>	
Number of Motor Phase	Three Phase
Protection Class	IP68
Insulation Class	F
Motor Power	11
Power Frequency	50HZ
Rated Voltage (V)	380V
Rated Current (A)	22.9
Starting mode	direct boot
<b>Seal</b>	
Mechanical Seal	H-45
<b>Others</b>	
Weight (kg)	216



### Performance Curve 150WQ140-14-11W(I)

Manufacturer	CNP
Address	Yuhang District, Hangzhou, Zhejiang,
Contact	86-571-88637351
Date	2022/03/09
Client Name	DPA
Client Addr.	
Contacts	Alireza
Contact	

Project Name

Item NO

The hydraulic performance curve have been tested with Clean Water at 20°C, density 1000kg/m<sup>3</sup>, and at 1bar atmospheric pressure. ISO99062012 Grade 3B

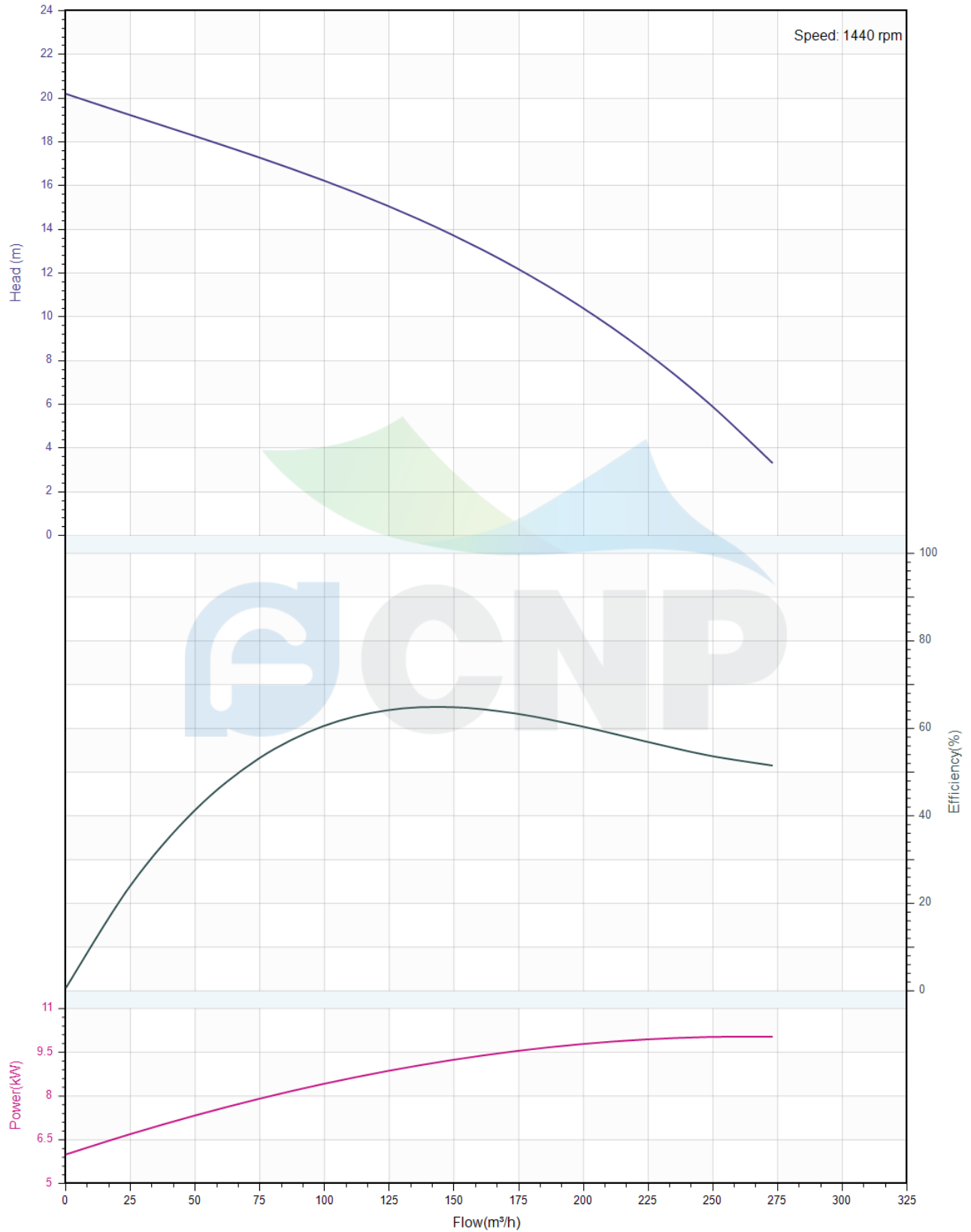



## Pump Technical Parameters 150WQ140-14-11W(I)

Manufacturer	CNP
Address	Yuhang District, Hangzhou, Zhejiang,
Contact	86-571-88637351
Date	2022/03/09
Client Name	DPA
Client Addr.	
Contacts	Alireza
Contact	

### Rated parameters

Pump model	150WQ140-14-11W(I)
Part NO.	150WQ140-14-11W(I)
Rated flow (m <sup>3</sup> /h)	140
Rated head (m)	14
Rated efficiency (%)	60.2
Power (kW)	8.87
Speed (rpm)	1440

### Medium

Pumped medium	Clean Water
Working temperature (°C)	20
Medium density (kg/m <sup>3</sup> )	1000
Viscosity (mm <sup>2</sup> /s)	1

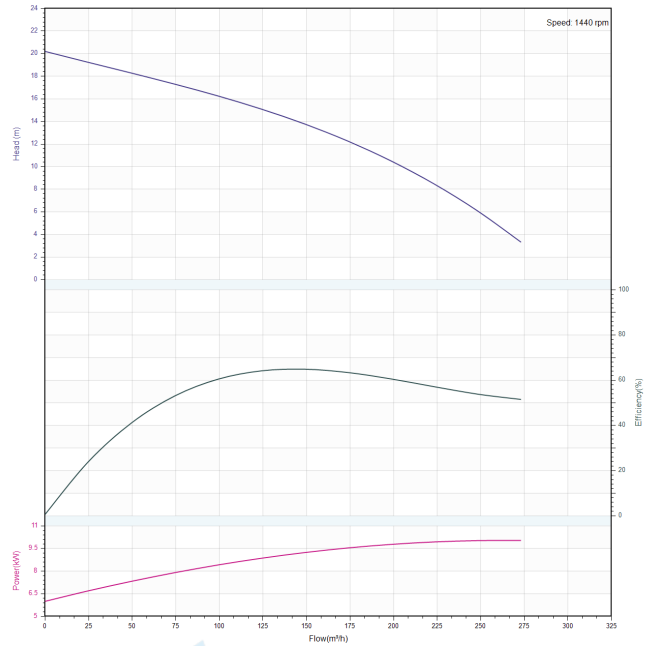

	<b>Structure picture</b> <b>150WQ140-14-11W(I)</b>	Manufacturer	CNP
		Address	Yuhang District, Hangzhou, Zhejiang,
		Contact	86-571-88637351
		Date	2022/03/09
Project Name		Client Name	DPA
Item NO		Client Addr.	
		Contacts	Alireza
		Contact	

**CNP Nanfang Zhongjin Environment Co., Ltd.**

	<b>SECTIONAL DRAWING</b>	No.	No.
TYPE	submersible sewage pump	MODEL	WQ-11/15kW

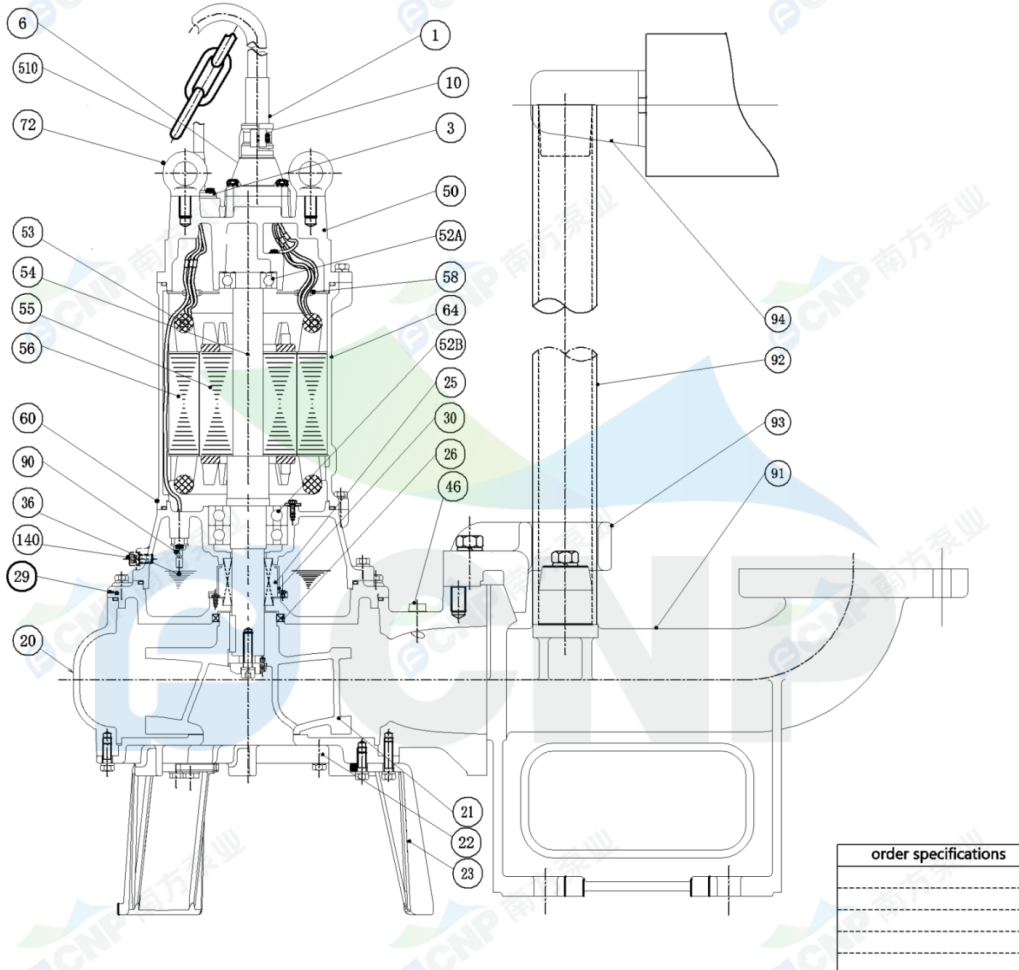

order specifications	

No.	names of parts	number	material	No.	names of parts	number	material
1	cable	1	YZW	22	water inlet cover	1	HT200
3	cable cover	1	SUS304	23	foot bracket	1	HT200
50	top cover	1	HT200	37	water outletbend	1	HT200(unaffiliated)
52A	upper bearing	1		20	casing	1	HT200
58	cable transit	1	PPS	29	Casingtop cover	1	HT200
64	board base	1	HT200	140	oil filler plug	1	SUS304
52B	lower bearing	1		36	machine oil 32#		
25	mechanical seal	1	Carbon/ceramics/SIC	90	Leak sensor electrode bar	1	
30	oil lift	1		60	lower cover	1	HT200
26	framework oil seal	1	NBRI-2	56	stator	1	
46	Air release bolt	1		55	rotor	1	
94	guiding	1	HT200	54	shaft	1	
92	pipe	1	SUS304(unaffiliated)	53	Mini-thermalprotector	1	
93	guide hook	1	HT200	72	eye bolt	2	45#(forging galvanized)
91	water outlet base	1	HT200	510	lift chain	1	SUS304
21	impeller	1	HT200	10	Cable lockblock	2	HT200
6	cable sleeve	2	HT200				

Nanfang Zhongjin Environment CO.,LTD.

unit : mm



## Installation picture 150WQ140-14-11W(I)

Manufacturer	CNP
Address	Yuhang District, Hangzhou, Zhejiang,
Contact	86-571-88637351
Date	2022/03/09
Client Name	DPA
Client Addr.	
Contacts	Alireza
Contact	

Project Name

Item NO

**CNP Nanfang Zhongjin Environment Co., Ltd.**

DIMENSION DRAWING		No.	No.
TYPE	submersible sewage pump	MODEL	150WQ140-14-11W
MODEL	d A A1 A2 A3 A4 A5 B B1 D D1 W1 W2 H	Body weight	216kg
150WQ140-14-11W	150 825 884 243 332 582 598 535 518 490 245 813 430 1097		

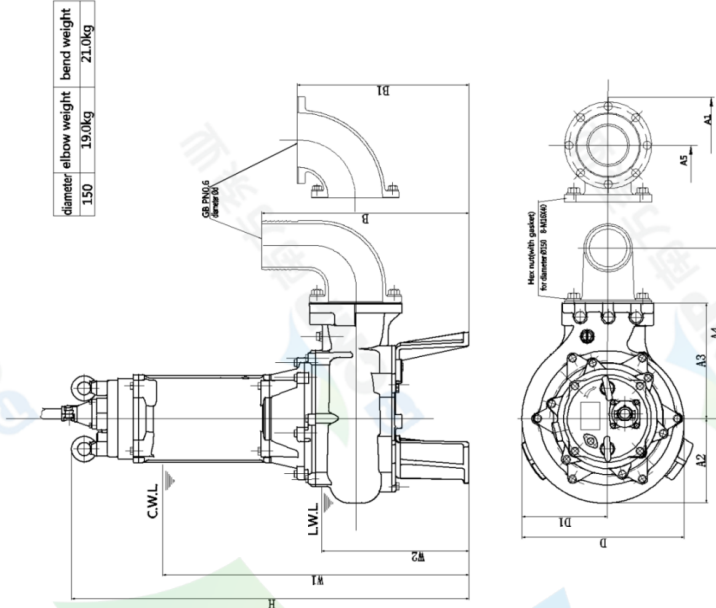

C.W.L.: minimum water level under continuous operation  
L.W.L.: minimum water level under possible operation

unit : mm

Nanfang Zhongjin Environment CO.,LTD.

**CNP Nanfang Zhongjin Environment Co., Ltd.**

DIMENSION DRAWING		No.	No.
TYPE	submersible sewage pump	MODEL	150WQ140-14-11W
MODEL	d A A1 A2 A3 A4 A5 B B1 D D1 W1 W2 H	Body weight	216kg
150WQ140-14-11W	150 825 884 243 332 582 598 535 518 490 245 813 430 1097		

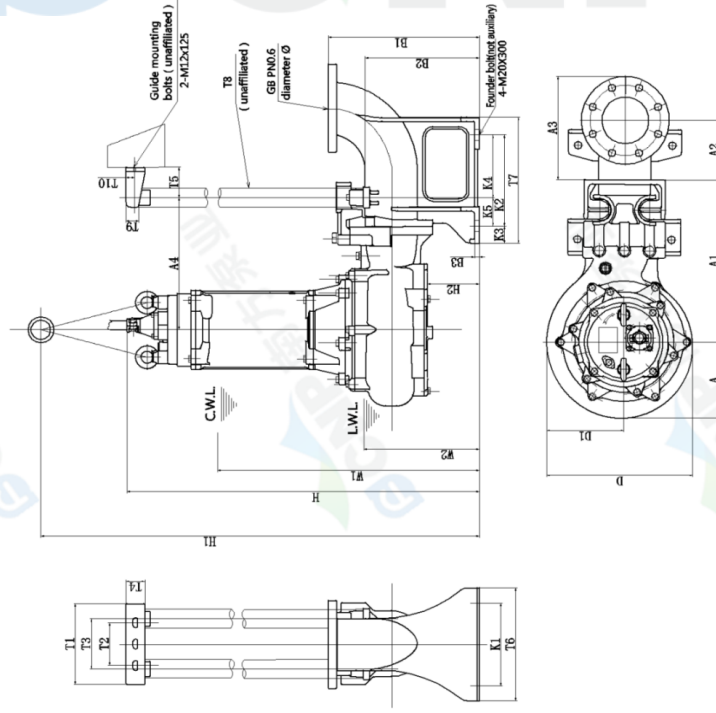

C.W.L.: minimum water level under continuous operation  
L.W.L.: minimum water level under possible operation

unit : mm

Nanfang Zhongjin Environment CO.,LTD.