	Product Information 150WQ100-17-7.5(I)	Manufacturer	CNP
		Address	Yuhang District, Hangzhou, Zhejiang,
Project Name		Contact	86-571-88637351
		Date	2022/03/09
Item NO		Client Name	DPA
		Client Addr.	
		Contacts	Alireza
		Contact	

Part NO.	150WQ100-17-7.5(I)
----------	--------------------

Product Picture	Note
	<p>The sewage submersible pump is composed of two parts: the motor and the pump.</p> <p>The two are separated by an oil chamber and a mechanical seal assembly.</p> <p>Divided into fixed automatic coupling installation and mobile installation</p>

technology	
Pump rotator speed	2940
Nameplate standards	CE
Material	
Impeller	HT200
Pump shaft	20cr13
Rubber code	P
Pump case	HT200
Installation	
Connection Code	F
Maximum Pressure/Temperatu	6bar/40
Flange Standard	DIN
Pressure Class	PN6
Medium	
Medium Temperature	40
Maximum diameter of partic	31
Maximum Environment Temper	40
Structure dimension	
Standard caliber	DN
Outlet Diameter	DN150
Motor	
Number of Motor Phase	Three Phase
Protection Class	IP68
Insulation Class	F
Motor Power	7.5
Power Frequency	50HZ
Rated Voltage (V)	380V
Rated Current (A)	14.3
Starting mode	direct boot
Seal	
Mechanical Seal	H-30
Others	
Weight (kg)	109



Performance Curve 150WQ100-17-7.5(I)

Manufacturer	CNP
Address	Yuhang District, Hangzhou, Zhejiang,
Contact	86-571-88637351
Date	2022/03/09
Client Name	DPA
Client Addr.	
Contacts	Alireza
Contact	

Project Name

Item NO

The hydraulic performance curve have been tested with Clean Water at 20°C, density 1000kg/m³, and at 1bar atmospheric pressure. ISO99062012 Grade 3B

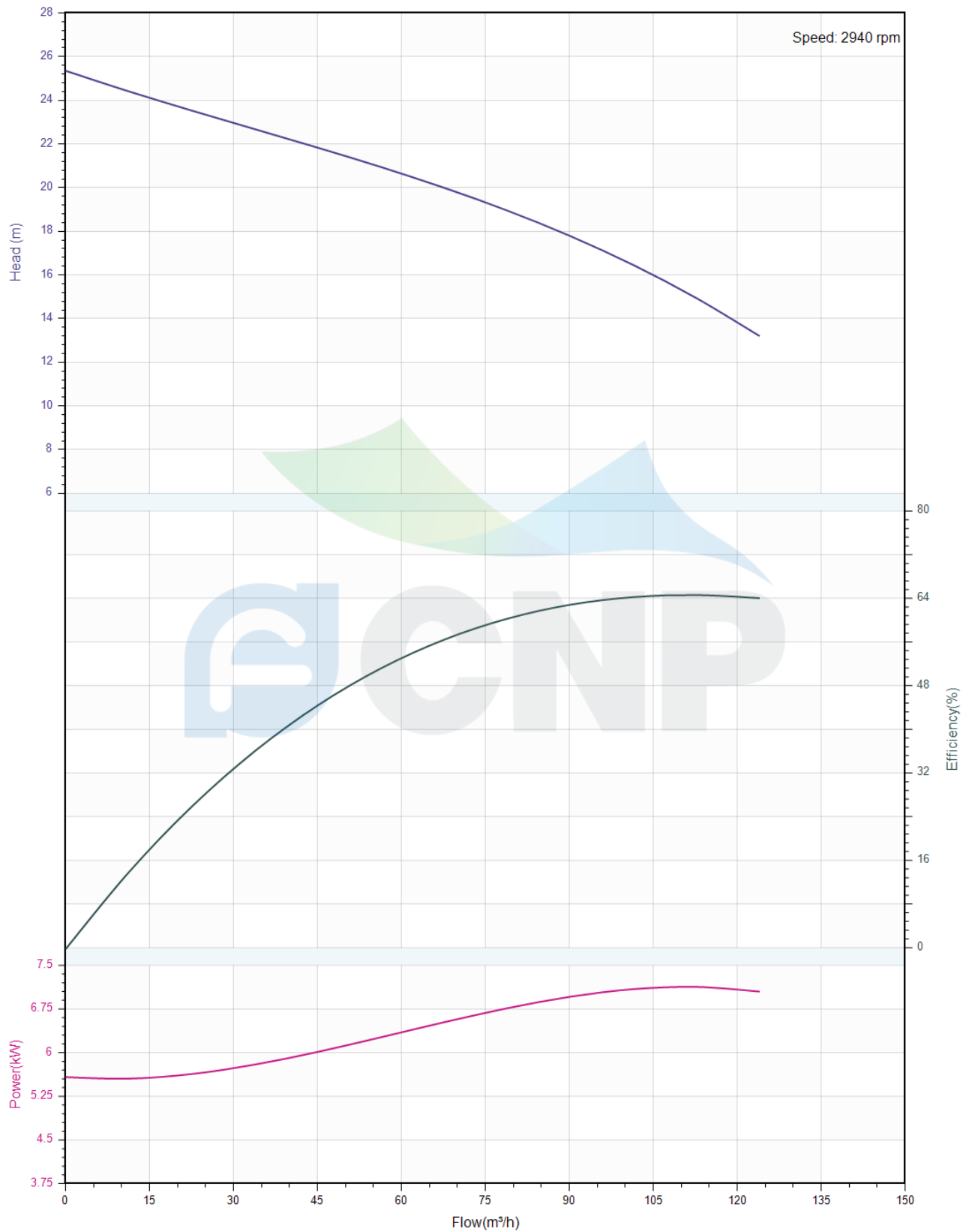



Pump Technical Parameters 150WQ100-17-7.5(I)

Manufacturer	CNP
Address	Yuhang District, Hangzhou, Zhejiang,
Contact	86-571-88637351
Date	2022/03/09
Client Name	DPA
Client Addr.	
Contacts	Alireza
Contact	

Rated parameters

Pump model	150WQ100-17-7.5(I)
Part NO.	150WQ100-17-7.5(I)
Rated flow (m ³ /h)	100
Rated head (m)	17
Rated efficiency (%)	71.2
Power (kW)	6.72
Speed (rpm)	2940

Medium

Pumped medium	Clean Water
Working temperature (°C)	20
Medium density (kg/m ³)	1000
Viscosity (mm ² /s)	1

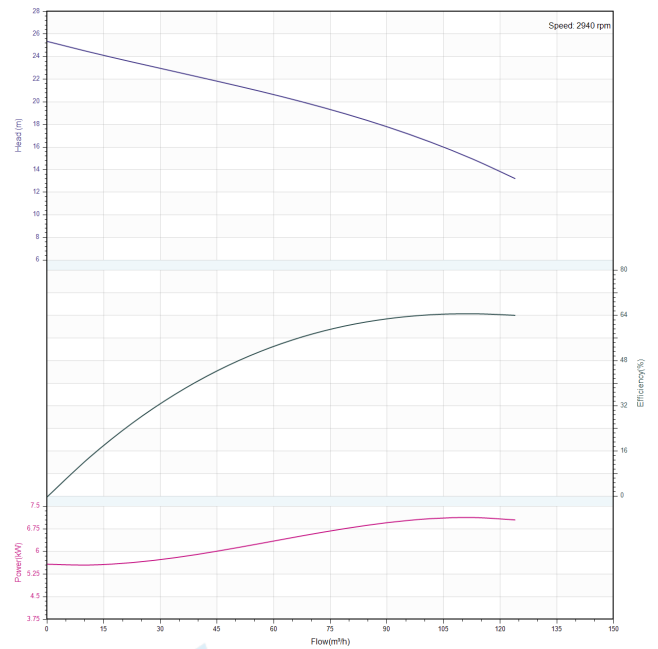

	Structure picture 150WQ100-17-7.5(I)	Manufacturer	CNP
		Address	Yuhang District, Hangzhou, Zhejiang,
		Contact	86-571-88637351
		Date	2022/03/09
Project Name		Client Name	DPA
Item NO		Client Addr.	
		Contacts	Alireza
		Contact	

CNP Nanfang Zhongjin Environment Co., Ltd.

	SECTIONAL DRAWING	No.	No.
TYPE	submersible sewage pump	MODEL	WQ-5.5/7.5kW

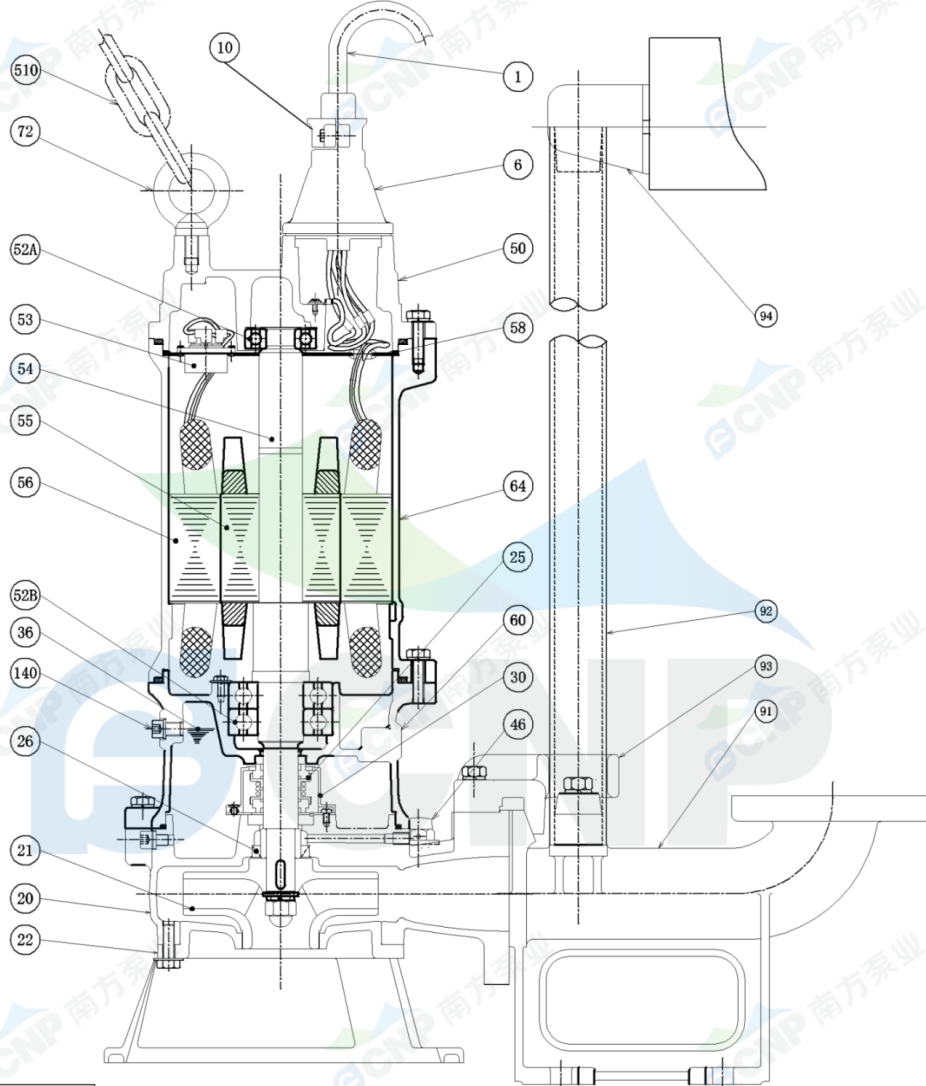

order specifications

No.	names of parts	number	material	No.	names of parts	number	material
1	cable	1	YZW	20	casing	1	HT200
6	cable sleeve	1	HT200	21	impeller	1	HT200
50	top cover	1	HT200	26	framework oil seal	1	NBRI-2
58	cable transit board	1	Q235	140	oil filler plug	2	SUS304
64	base	1	HT200	36	machine oil 32#		
25	mechanical seal	1	Carbon/SIC	52B	lower bearing	2	
60	lower cover	1	HT200	56	stator	1	
30	oil lift	1		55	rotor	1	
46	Air release bolt	1		54	shaft	1	
94	guiding	1	HT200	53	thermal protector	1	
92	pipe	1	SUS304(unaffiliated)	52A	upper bearing	1	
93	guide hook	1	HT200	72	eye bolt	2	45#(forging galvanized)
91	water outlet base	1	HT200	510	lift chain	1	SUS304
22	water inlet cover	1	HT200	10	Cable lockblock	2	HT200

Nanfang Zhongjin Environment CO.,LTD.

unit : mm



Installation picture 150WQ100-17-7.5(I)

Manufacturer	CNP
Address	Yuhang District, Hangzhou, Zhejiang,
Contact	86-571-88637351
Date	2022/03/09
Client Name	DPA
Client Addr.	
Contacts	Alireza
Contact	

Project Name

Item NO

CNP Nanfang Zhongjin Environment Co., Ltd.

DIMENSION DRAWING		No.	No.
TYPE submersible sewage pump		MODEL	150WQ100-17-7.5

MODEL	d	A	A1	A2	A3	A4	A5	B	B1	D	D1	W1	W2	H	Body weight
WQ100-17-7.5	150	650	708	163	163	245	422	422	483	365	163	510	214	850	109kg

diameter elbow weight	19kg
bend weight	21kg

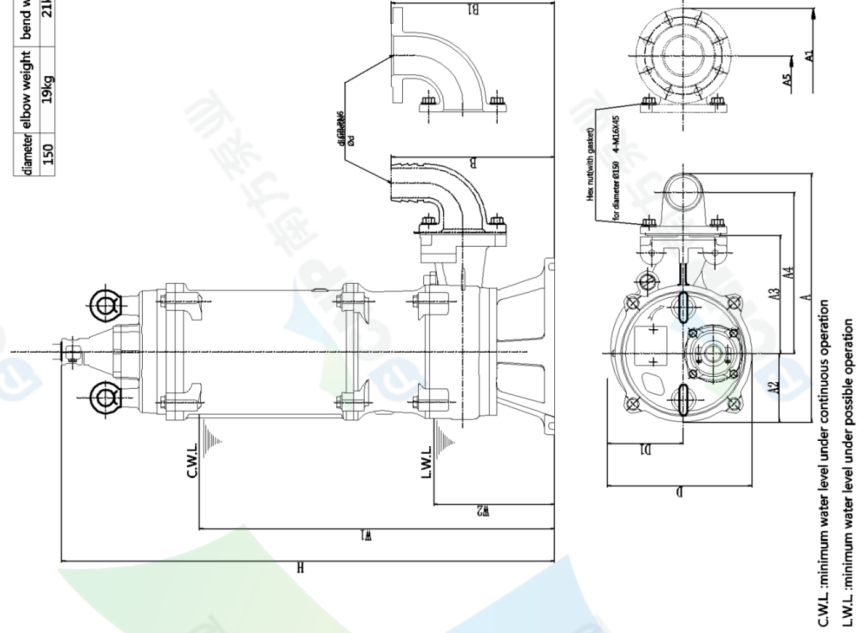

C.W.L.: minimum water level under continuous operation
L.W.L.: minimum water level under possible operation

Nanfang Zhongjin Environment CO.,LTD. unit : mm

CNP Nanfang Zhongjin Environment Co., Ltd.

DIMENSION DRAWING		No.	No.
TYPE submersible sewage pump		MODEL	150WQ100-17-7.5

MODEL	A	A1	A2	A3	A4	D	D1	W1	W2	H	H1	H2	Body weight
150WQ100-17-7.5	150	465	173	173	240	310	159	635	340	976	1305	65	80kg
150WQ100-17-7.5	150	228	138	138	200	276	137	300	160	460	388	15	63.5kg

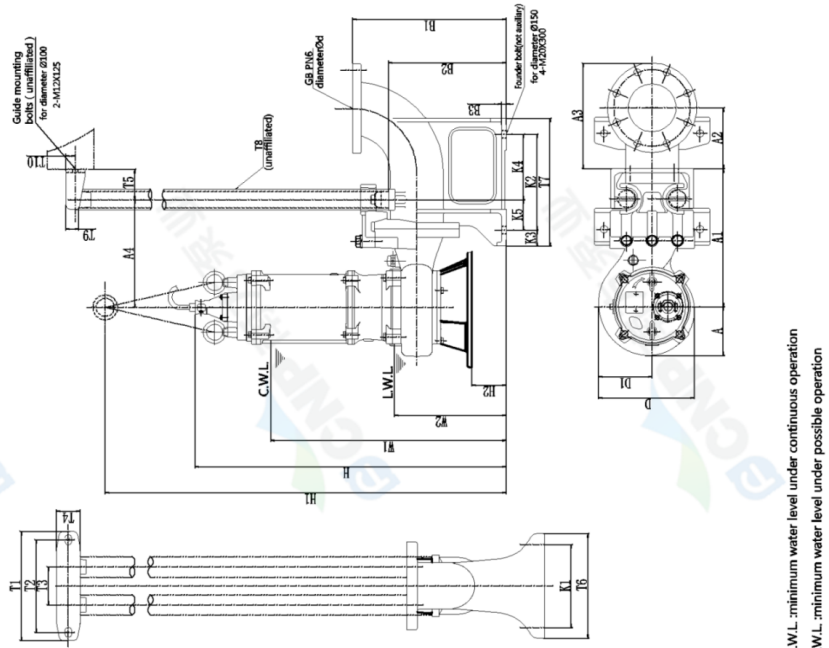

C.W.L.: minimum water level under continuous operation
L.W.L.: minimum water level under possible operation

Nanfang Zhongjin Environment CO.,LTD. unit : mm