	<b>Product Information</b> <b>100WQ100-29-15H(I)</b>	Manufacturer	CNP
		Address	Yuhang District, Hangzhou, Zhejiang,
<b>Project Name</b>		Contact	86-571-88637351
		Date	2022/03/09
<b>Item NO</b>		Client Name	DPA
		Client Addr.	
		Contacts	Alireza
		Contact	

Part NO.	100WQ100-29-15H
----------	-----------------

Product Picture	Note
	<p>The sewage submersible pump is composed of two parts: the motor and the pump.</p> <p>The two are separated by an oil chamber and a mechanical seal assembly.</p> <p>Divided into fixed automatic coupling installation and mobile installation</p>

<b>technology</b>	
Pump rotator speed	1440
Nameplate standards	CE
<b>Material</b>	
Impeller	HT200
Pump shaft	20cr13
Rubber code	P
Pump case	HT200
<b>Installation</b>	
Connection Code	F
Maximum Pressure/Temperatu	6bar/40
Flange Standard	DIN
Pressure Class	PN6
<b>Medium</b>	
Medium Temperature	40
Maximum diameter of partic	55
Maximum Environment Temper	40
<b>Structure dimension</b>	
Standard caliber	DN
Outlet Diameter	DN100
<b>Motor</b>	
Number of Motor Phase	Three Phase
Protection Class	IP68
Insulation Class	F
Motor Power	15
Power Frequency	50HZ
Rated Voltage (V)	380V
Rated Current (A)	30.6
Starting mode	direct boot
<b>Seal</b>	
Mechanical Seal	H-50
<b>Others</b>	
Weight (kg)	270



### Performance Curve 100WQ100-29-15H(I)

Manufacturer	CNP
Address	Yuhang District, Hangzhou, Zhejiang,
Contact	86-571-88637351
Date	2022/03/09
Client Name	DPA
Client Addr.	
Contacts	Alireza
Contact	

Project Name

Item NO

The hydraulic performance curve have been tested with Clean Water at 20°C, density 1000kg/m<sup>3</sup>, and at 1bar atmospheric pressure. ISO99062012 Grade 3B

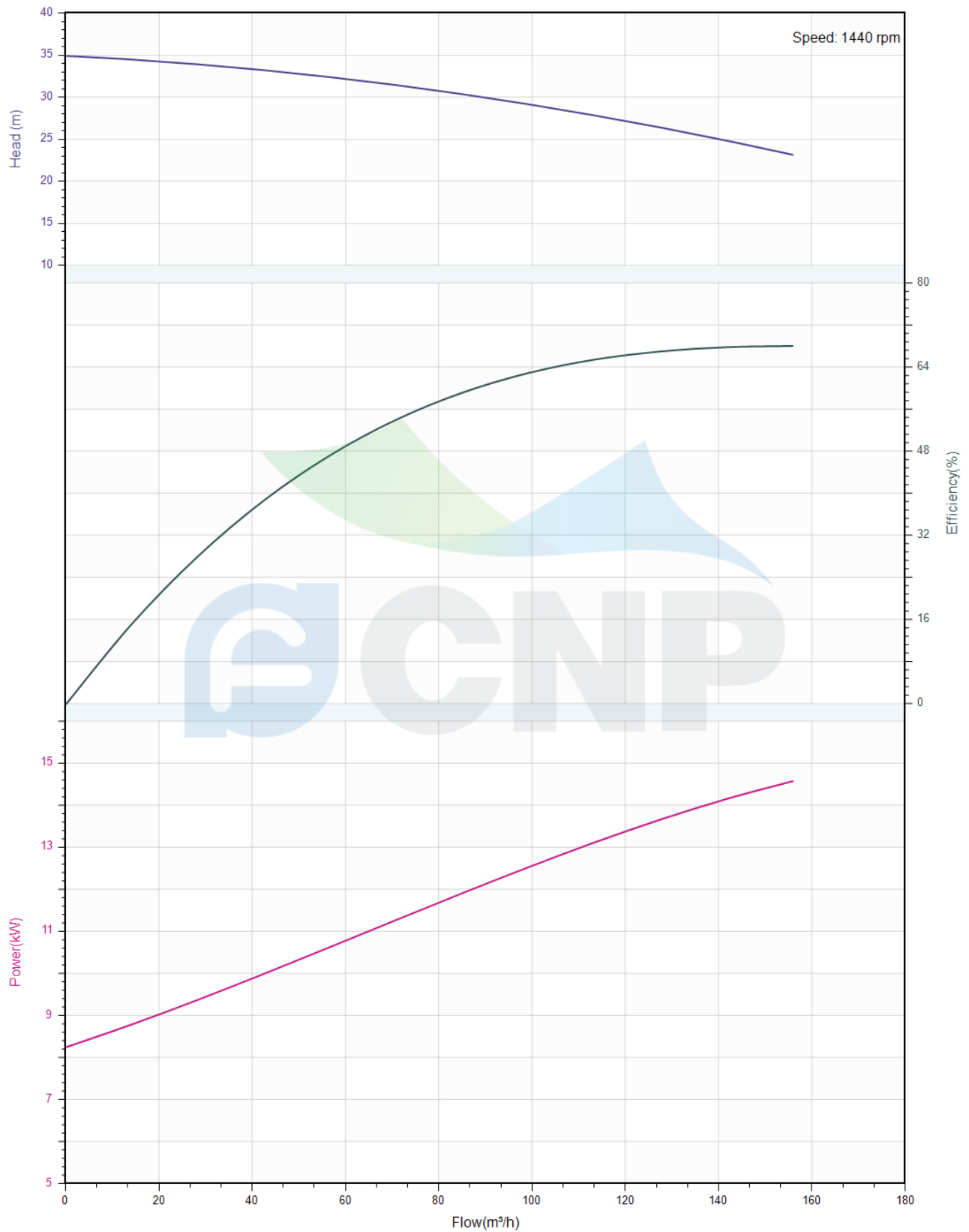



## Pump Technical Parameters 100WQ100-29-15H(I)

Manufacturer	CNP
Address	Yuhang District, Hangzhou, Zhejiang,
Contact	86-571-88637351
Date	2022/03/09
Client Name	DPA
Client Addr.	
Contacts	Alireza
Contact	

### Rated parameters

Pump model	100WQ100-29-15H(I)
Part NO.	100WQ100-29-15H
Rated flow (m <sup>3</sup> /h)	100
Rated head (m)	29
Rated efficiency (%)	63
Power (kW)	12.54
NPSHr (m)	2
Speed (rpm)	1440

### Medium

Pumped medium	Clean Water
Working temperature (°C)	20
Medium density (kg/m <sup>3</sup> )	1000
Viscosity (mm <sup>2</sup> /s)	1

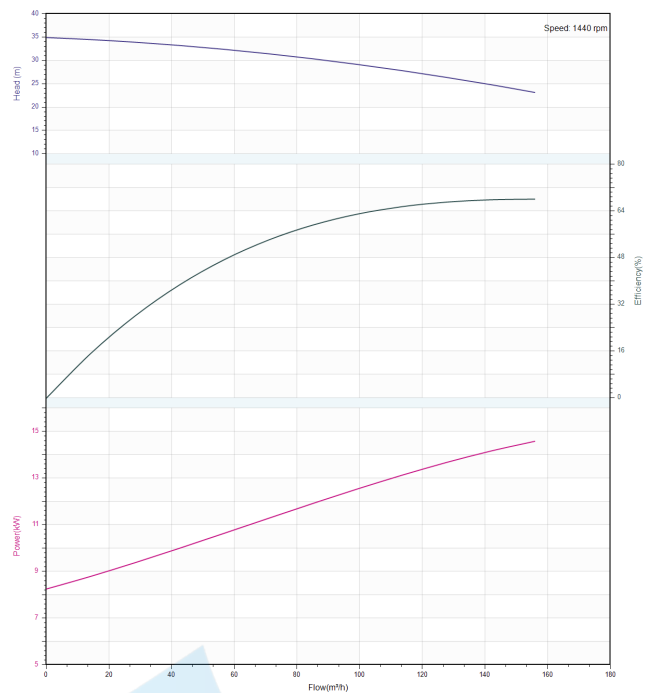

	<b>Structure picture</b> <b>100WQ100-29-15H(I)</b>	Manufacturer	CNP
		Address	Yuhang District, Hangzhou, Zhejiang,
		Contact	86-571-88637351
		Date	2022/03/09
Project Name		Client Name	DPA
Item NO		Client Addr.	
		Contacts	Alireza
		Contact	

## CNP Nanfang Zhongjin Environment Co., Ltd.

	<b>SECTIONAL DRAWING</b>	No.	No.
TYPE	submersible sewage pump	MODEL	WQ-11/15kW

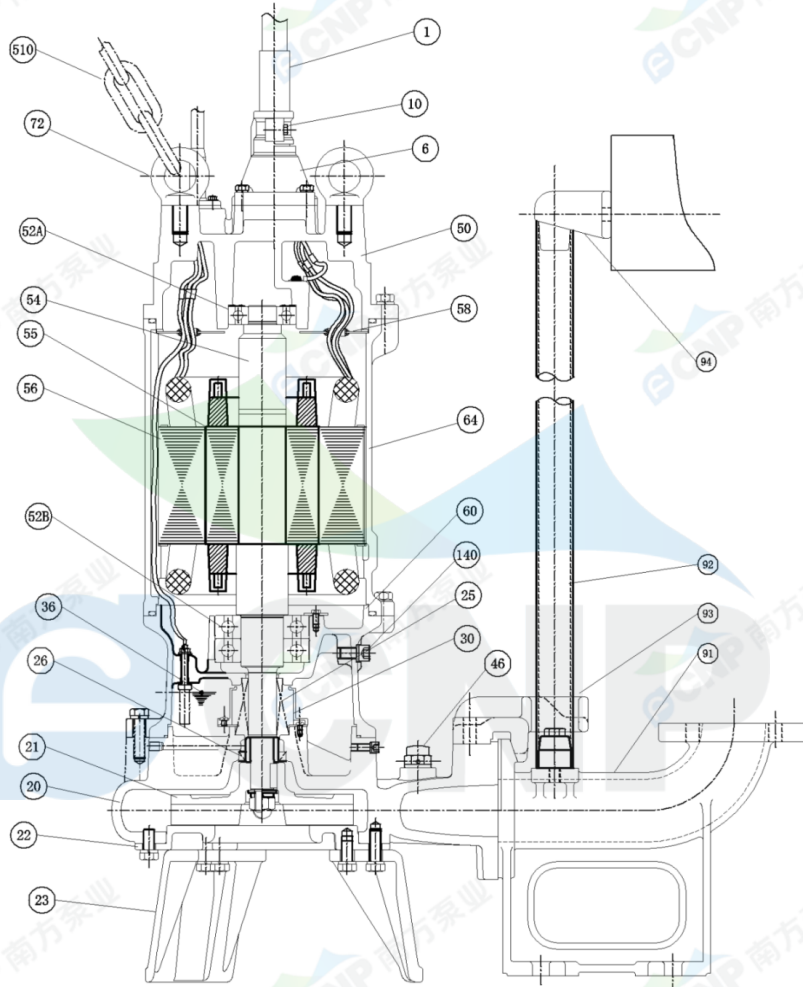

order specifications	

No.	names of parts	number	material	No.	names of parts	number	material
1	cable	1	YZW	20	casing	1	HT200
6	cable sleeve	1	HT200	21	impeller	1	HT200
50	top cover	1	HT200	26	framework oil seal	1	NBR-2
58	cable transit board	1	Q235	140	oil filler plug	2	SUS304
64	base	1	HT200	36	machine oil 32#		
25	mechanical seal	1	Carbon/SIC	52B	lower bearing	2	
60	lower cover	1	HT200	56	stator	1	
30	oil lift	1		55	rotor	1	
46	Air release bolt	1		54	shaft	1	
94	guiding	1	HT200	52A	upper bearing	1	
92	pipe	1	SUS304(unaffiliated)	72	eye bolt	2	SUS304
93	guide hook	1	HT200	510	lift chain	1	45#(forging galvanized)
91	water outlet base	1	HT200	23	foot bracket	3	HT200
22	water inlet cover	1	HT200	10	Cable lockblock	2	HT200

Nanfang Zhongjin Environment CO.,LTD.

unit : mm



### Installation picture 100WQ100-29-15H(I)

Manufacturer	CNP
Address	Yuhang District, Hangzhou, Zhejiang,
Contact	86-571-88637351
Date	2022/03/09
Client Name	DPA
Client Addr.	
Contacts	Alireza
Contact	

Project Name

Item NO

CNP 中金环境

外形尺寸		DIMENSION DRAWING		No.											
TYPE 名称		污水污物潜水泵		MODEL 型号											
				100WQ100-29-15H											
型号	d	A	A1	A2	A3	A4	A5	B	B1	D	D1	W1	W2	H	总重量
100	100	695.5	776	331	312	327	671	457.5	442.5	480	245	990	370	1114	280kg

口径	重量	连接重量
100	6.5kg	10.5kg

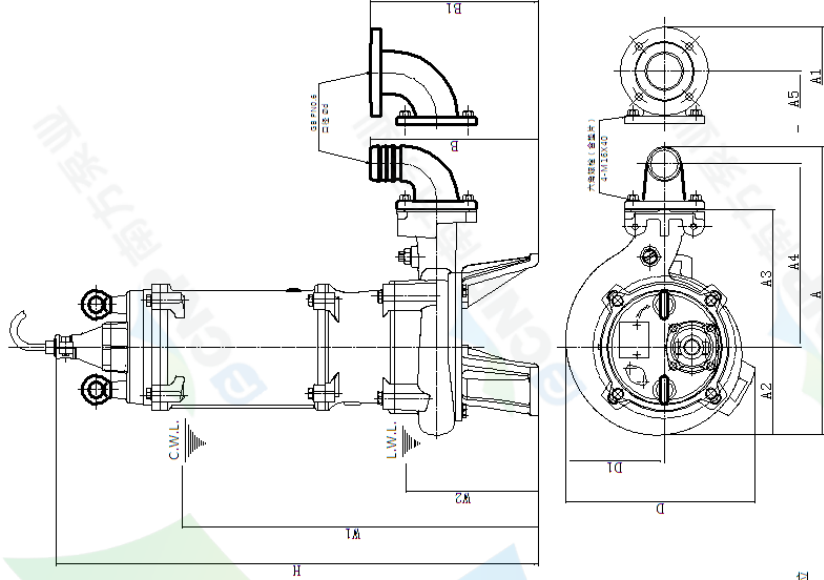

C.W.L.:连续运行最低水位  
L.W.L.:可能运行最低水位

南方中金环境股份有限公司 Nanfang Zhongjin Environment CO.,LTD. unit : mm

CNP 中金环境

安装外形尺寸		DIMENSION DRAWING		No.									
TYPE 名称		污水污物潜水泵		MODEL 型号									
				100WQ100-29-15H									
型号	A	A1	A2	A3	A4	D	D1	W1	W2	H	H1	H2	总重量
100WQ100-29-15H	331	436	181	286	341	480	245	917.5	297.5	1041.5	1441.5	72.5	280kg
尺寸范围	100	100	100	100	100	100	100	100	100	100	100	100	100
100	300	245	100	60	95	250	290	2760x3.5	40	30	200	1200	45
	181	19	340	285	15	35kg							

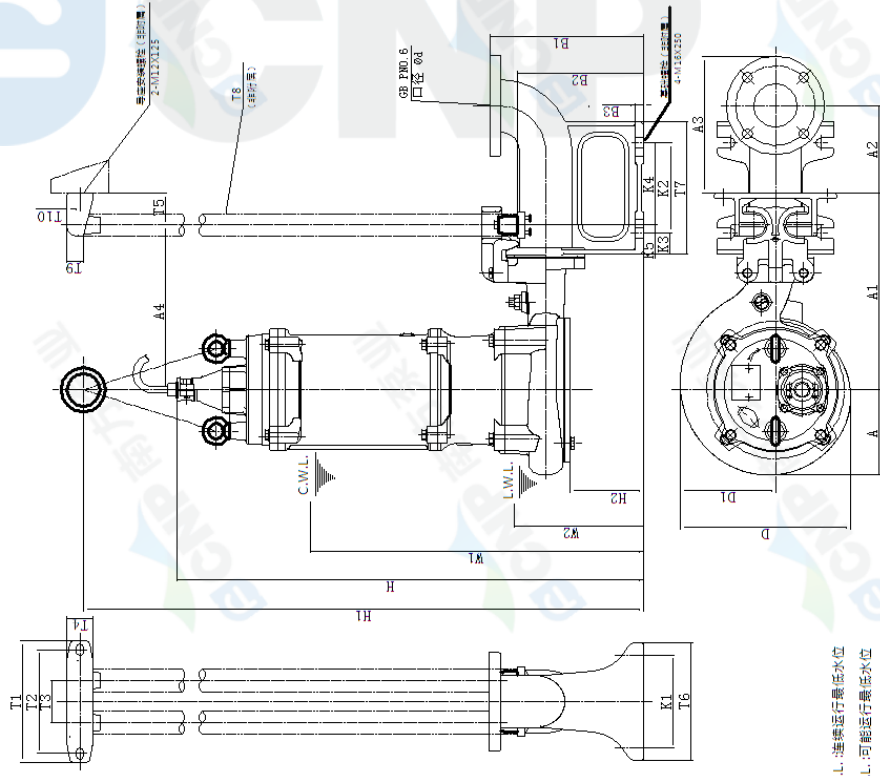

C.W.L.:连续运行最低水位  
L.W.L.:可能运行最低水位

南方中金环境股份有限公司 Nanfang Zhongjin Environment CO.,LTD. unit : mm