

VTP

Vertical Turbine Pump



NANFANG PUMP INDUSTRY CO., LTD.

CNP Headquarter
Add: Renhe Town, Hangzhou China
Postcode: 311107
Tel: +86 571 86397810, 86397838
Fax: +86 571 86397809
Email: info@nanfang-pump.com
Website: www.cnppump.com

CNP CHANGSHA CO.,LTD.

Add: Changsha, Hunan, China
Postcode: 410100
Tel: +86 731 86912839
Fax: +86 731 86912839
Email: ch-sales2@nanfang-pump.com
Website: www.cnp-changsha.com

NANFANG PUMP INDUSTRY CO., LTD.



Vertical Turbine Pumps

The 4 different model vertical turbine pumps have one thing in common the hydraulic design of the pump bowl assembly. Using a new techniques in turbine pump design. It covers a wide range of hydraulic conditions to meet virtually every pumping service with optimum efficiency.

CNP flexibility of design allows the use of a wide range of material and design features to meet the custom requirements of user. No matter what the requirements, whether low first cost, ease of maintenance, optimum efficiency. Tough service conditions, CNP can make the pump to best satisfy the requirements.

- VTC Centrifugal or mixed-flow pump for high pressure
- VTM Mixed-flow pump for high flow and middle pressure
- VTA Axial-flow pump for high flow low pressure
- VTG Pump for fire and marine gear box engine driven

Model VTC

Vertical Industrial Turbine Pumps

VTC series is a single or multistage pump with centrifugal or mixed-flow enclosed type impeller, designed for high pressure services.



Model VTM

High Capacity Vertical Turbine Pumps

VTM series is a single stage pump with mixed-flow semi-open or enclosed type impeller, designed for high capacity, medium to high head services.



Model VTA

Low Head Vertical Turbine Pumps

VTA series is a single stage pump with axial-flow impeller, designed for high capacity, low head services.

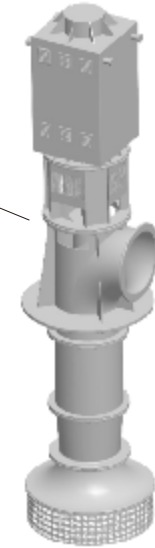

Model VTG

Right Angle Gear Box Driven Vertical Turbine Pumps

VTG series is vertical turbine pump designed for engine driven through a right angle gear box, for the place where electric power is not available services.

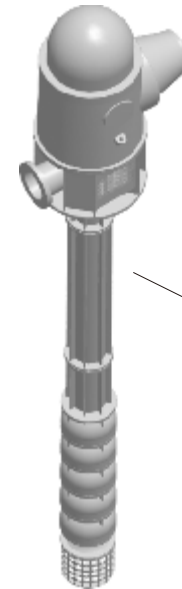

Standard Design Features Of VTP

The bowl assembly is the heart of the VTP. The impeller and diffuser type casing are designed to deliver the head and capacity that your system requires in the most efficient way possible. The fact that the VTP can be multi-staged allows maximum flexibility both in the initial pump selection and in the event that future system modifications require a change in the pump rating. Submerged impellers allow pump to be started without priming.

A variety material options allows the selection of a pump best suited for even the most severe services. The many bowl assembly options available assure that the VTP satisfies the user's need for safe, efficient, reliable and maintenance-free operation.

1. Strainers

316SS Basket strainers to provide protection from large solids.

2. Suction bell

Allows smooth entry of liquid into impeller eye, minimizes vortex formation. Scotchkote custom fusion bonded epoxy coating inside.

3. Suction bell bearing

Provided for shaft stability.

4. Sand collar

Prevents solids from entering suction bearing.

5. Impeller

Hydraulic balancing to reduce axial down thrust and achieve long thrust bearing life. Dynamic balancing of impellers are available.

6. Pump shaft

Heavy duty, 416SS standard, other alloys for strength and corrosion resistance. Hollow pump shaft with flushing hole special for bearing flushing on corrosive/abrasive services.

7. Diffuser bowl

Available in variety of cast material. Scotchkote custom fusion bonded epoxy coating inside to improved the efficiency and longer life. Registered fits assure positive alignment, ease of maintenance.

8. Sleeve type bearing

Provided at each stage to assure stable operation away from critical speed.

9. Wear rings

Dual wear rings for enclosed impellers and bowls, permits re-establishing initial running clearances and efficiency at lower cost. Hard facing of wear surface available for longer life. Wear ring can be flushed when solids are present in the pumping liquid.

10. Keyed impeller

Keyed impeller for all the pumps, suitable for pumping liquid in high temperatures. Keyed impellers provide ease if maintenance and positive locking under fluctuating load and temperature conditions.

11. Flanged column

Heavy duty seamless column pipe sections are provided with flanged ends incorporating registered fits for ease of alignment during assembly.

12. Lineshaft and coupling

a. Open lineshaft

Flanges column/product lubricated lineshaft is recommended for ease of maintenance or whenever a special bearing material is required. Precision keyed lineshaft coupling available in all sizes for ease of maintenance. Various bearing material available. Renewable shaft sleeve or hard facing of shaft available for longer life.

b. Enclosed lineshaft

The lineshaft is protected by water flushing tube, flushing water for bearing and wear ring on corrosive/abrasive services.

13. Bearing retainer and lineshaft bearing

Ductile cast iron bearing retainer for size smaller than 24". Various bearing material available.

14. Discharge head and motor riser

Discharge head and motor riser designed for all modes of drivers including hollow shaft or solid shaft motors, right angle gears, vertical steam turbines, etc. Fabricated elbow discharge head engineered to minimize losses. Large access holes provide easy access to coupling and stuffing box. Above ground and below ground discharge head for requirement.

15. Thrust bearing

Oil lubricated thrust bearing assembly set with water cooling system make the pumps running safely in longer life

16. Packing box

Whenever packing lubrication leakage can be tolerated and the discharge pressure does not exceed 300psi, a packed box may be used. Optional headshaft sleeve available to protect shaft.

17. Coupling for pump and motor

Flexible coupling for pump and motor when pump with thrust bearing. impeller adjustment by the nut on the top shaft.

VTC, VTG Industrial Turbine Pumps

Specification range

- Capacities to 5500m³/h (24,000GPM)
- Heads to 300m (980ft)
- Temperatures to 80°C(176°F)

Design Advantages

1. Fabricated discharge head for 10" or larger sizes. Suitable for temperature liquid pumping.
2. Seamless flanged ends column pipe and flanges bowl construction incorporating registered fits for ease of assembly during assembly.
3. Alloy construction with external tube flush of critical wear areas available for abrasive services.
4. Build-in alignment and simple piping for less costly installation and ease of maintenance reduced downtime.
5. 416SS shafting. Keyed lineshaft coupling available in all size for ease of maintenance.

6. The lineshaft can be protected by water flushing the enclosing tube bearing on corrosive/abrasive services.
7. Various bearing material available.
8. Renewable shaft sleeve or hard facing of shaft available for long life.
9. Dual wear rings for impellers and bowls.

10. Hard facing wear surfaces available for longer life. Wear rings can be flushed when solids are present in pumpage.

11. Cooling Water
12. Seawater and Raw Water Intake
13. Industrial Process Pumps
14. Utility Circulating Water
15. Condenser Circulating Water Pumps
16. Ash Sluice
17. Fire-fighting

Services

1. Strainers
2. Suction bell
3. Suction bell bearing
4. Sand collar
5. Impeller
6. Keyed impeller
7. Pump shaft
8. Diffuser bowl
9. Wear ring
10. Sleeve type bearing

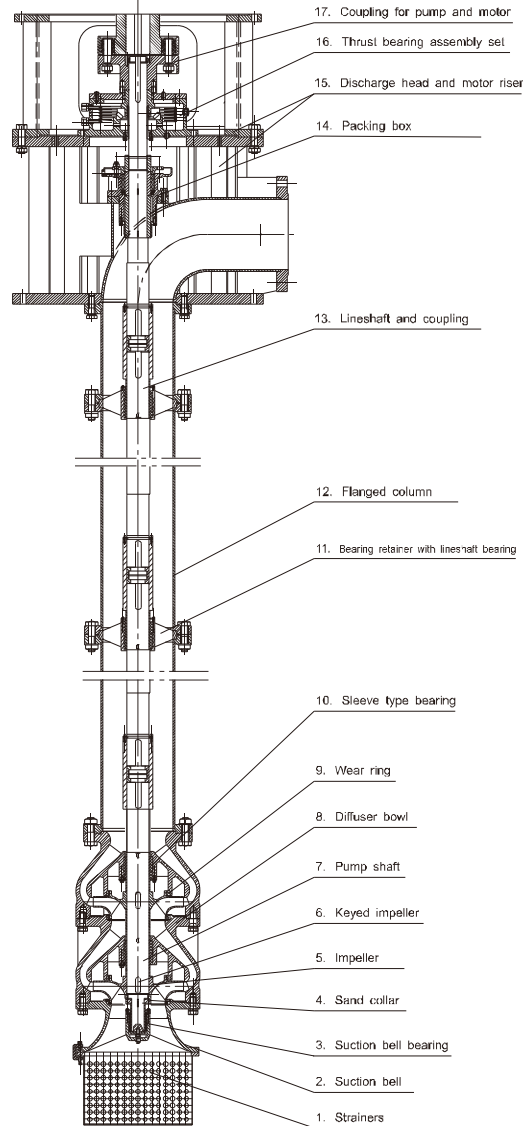

VTC Selection Charts

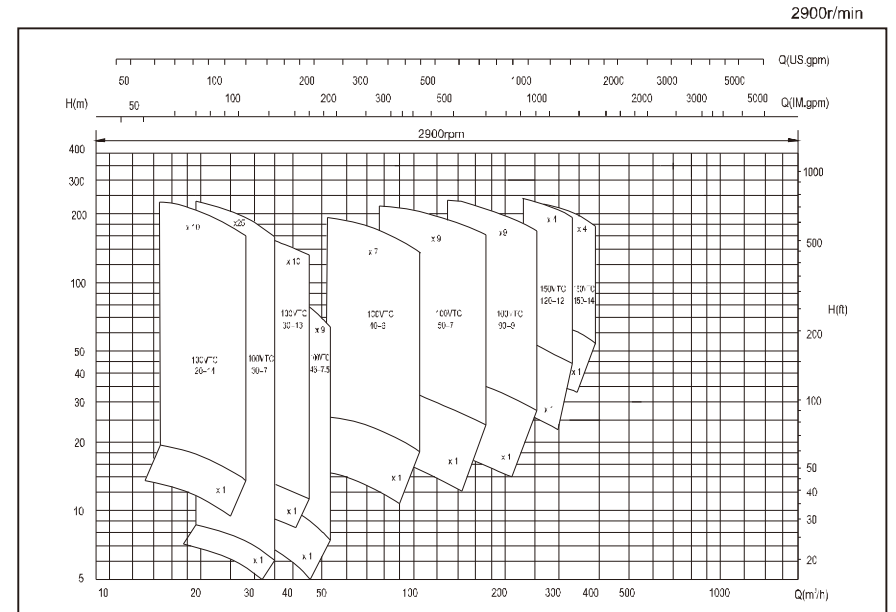

VTC Pump Bowl Assembly Dimensions

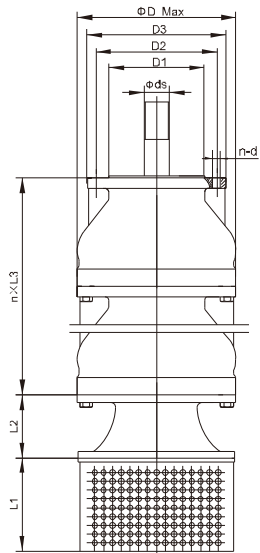

Model	D Max	L1	L2	L3	Max n	D1	D2	D3	Φds	n - φd
100VTC20-14	195	150	95	110	10	125h6	165	195	28	8-M12
100VTC30-7	133	200	80	90	25	132h6	160	200	22	8-Φ14
100VTC30-13	180	150	95	135	10	125h6	156	180	28	8-M12
100VTC40-6	245	225	90	180	10	130h6	210	220	30/35	8-M16
100VTC50-7	245	240	90	180	10	130h6	174	200	40	8-Φ13.5
100VTC90-9	245	240	90	225	6	130h6	174	200	40	8-Φ13.5
150VTC120-12	323	295	140	230	4	160h6	210	240	40	8-M16
150VTC150-14	323	292	140	230	4	160h6	210	240	40	8-M16
200VTC200-17	358	320	140	250	3	230h6	280	320	30/40	8-Φ23
200VTC250-22	420	320	165	300	5	230h6	280	320	50	8-Φ22
200VTC280-24	420	320	165	300	4	230h6	280	320	50	8-Φ22
250VTC400-28	477	340	185	330	8	280h6	330	370	60	12-Φ22
250VTC480-30	477	340	185	330	8	280h6	330	370	60	12-Φ22
250VTC550-26	430	320	170	365	7	280h6	330	370	60	12-Φ22
300VTC720-40	570	600	220	390	7	340h6	385	425	60/70/80	12-M20
300VTC820-29	480	320	170	475	7	340h6	385	425	60/70/90	12-Φ22
300VTC860-43	570	600	220	390	7	340h6	385	425	60/70/80	12-M20
300VTC900-25	435	600	170	513	5	340h6	385	425	50	12-Φ23
350VTC1000-51	630	370	250	430	7	395h6	440	480	70/90	16-M20
350VTC1200-32	550	320	250	600	4	395h6	440	480	60	16-M20
350VTC1250-36	550	320	250	550	5	395h6	440	480	70/80/90	16-Φ23
400VTC1650-28	670	400	280	720	3	440h6	500	550	70/80	16-M24
400VTC1750-48	620	400	280	615	4	440h6	500	550	80/90	16-M24
400VTC2100-35	550	320	250	600	4	440h6	500	550	70	16-M20
500VTC2200-32	755	550	250	750	5	550h6	600	650	90	16-Φ26
500VTC2400-57	965	480	390	675	4	550h6	600	650	90/100/120	16-Φ30
600VTC2800-26	718	550	450	550	3	660h6	725	780	80/100/110	20-Φ30
600VTC3300-50	880	320	280	760	2	650h6	700	745	90/100/110	16-Φ27
600VTC3600-32	810	550	330	870	2	650h6	700	745	90/100	16-M24
700VTC4800-56	1330	440	405	890	1	750h6	840	900	120/140	24-Φ30

VTC, VTG Pump Dimensions (Above Ground Discharge)

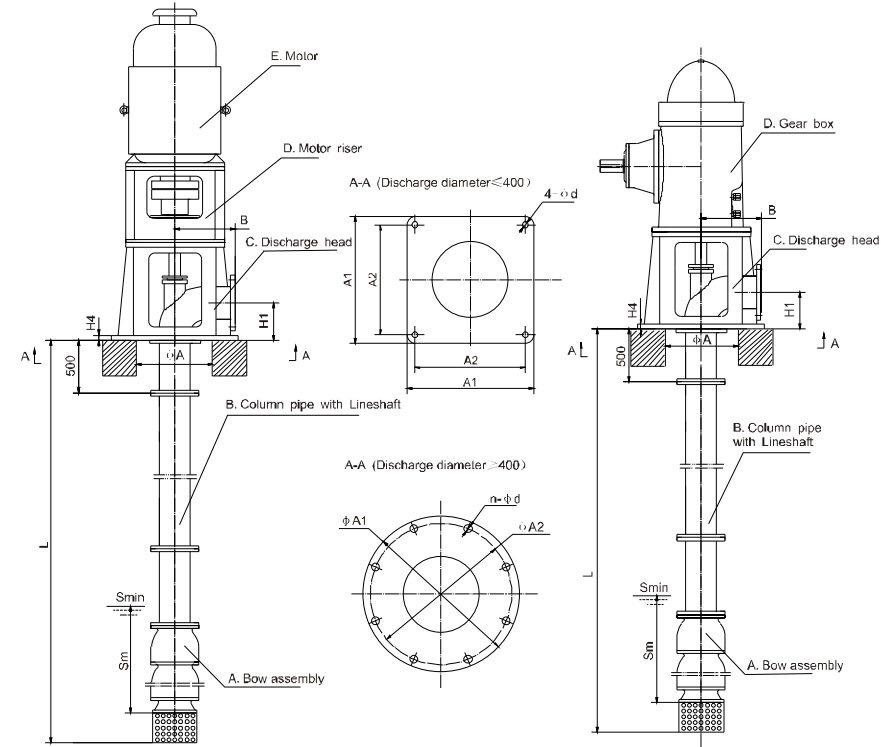

Model	A1	A2	n-φd	H1	H4	B	Sm	φA
100VTC	470	420	4-25	145	20	300	400	300
150VTC	550	500	4-25	165	25	350	450	380
200VTC	700	640	4-30	215	25	400	480	480
250VTC	780	720	4-30	265	30	450	700	550
300VTC	880	820	4-30	320	35	500	900	650
350VTC	930	870	4-30	370	35	550	1400	700
400VTC	1030	960	4-30	420	40	600	1800	700
500VTC	φ 1500	φ 1400	8-40	520	40	700	1800	1000
600VTC	φ 1600	φ 1500	12-40	620	45	850	2000	1100
700VTC	φ 1900	φ 1800	12-40	700	50	950	2200	1400

1. Discharge Flanges drilled to ISO, DIN, BS or ANSI.
2. 400 outlet diameter and below can directly use the table size, over 400 outlet diameter will be subject to overall dimension of CNP.
3. The final installation size will be subject the final overall dimension of CNP.

VTC, VTG Pump Dimensions (Below Ground Discharge)

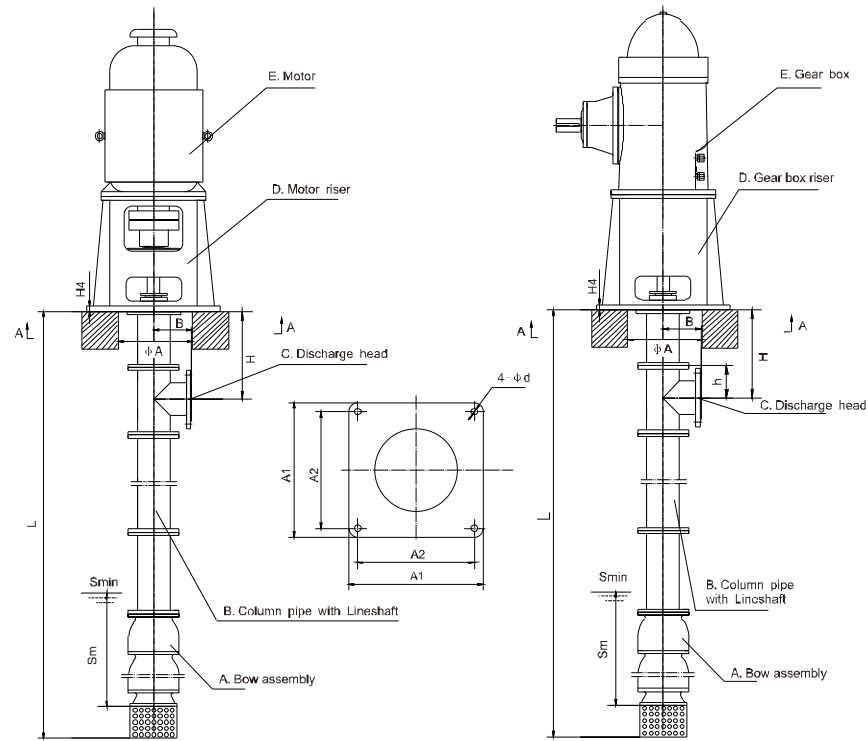

Model	A1	A2	φ d	h	B	Sm	φ A
100VTC	470	420	25	200	140	400	350
150VTC	550	500	25	200	180	450	420
200VTC	700	640	30	200	220	480	520
250VTC	780	720	30	240	280	700	600
300VTC	880	820	30	260	330	900	700
350VTC	930	870	30	300	380	1400	770
400VTC	1030	960	30	320	430	1800	850

1. Discharge Flanges drilled to ISO, DIN, BS or ANSI.
2. The final installation size will be subject to the final overall dimension of CNP.
3. The VTC series below ground discharge in principle is not recommended
4. Over 500 outlet diameter will be subject to overall dimension of CNP.

VTC, VTG Pump Curves (Single stage)

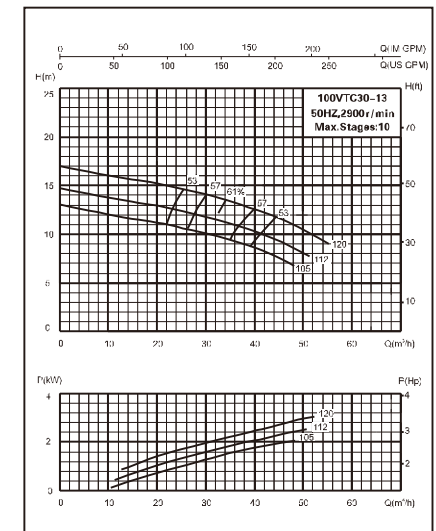
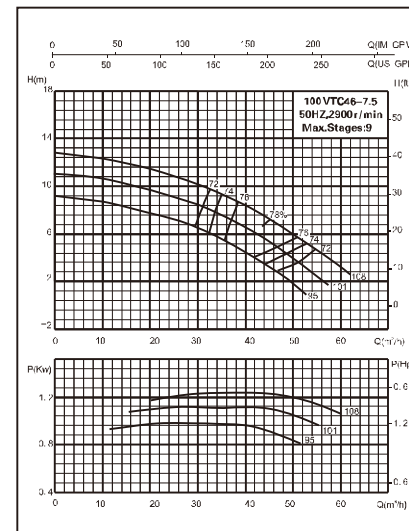
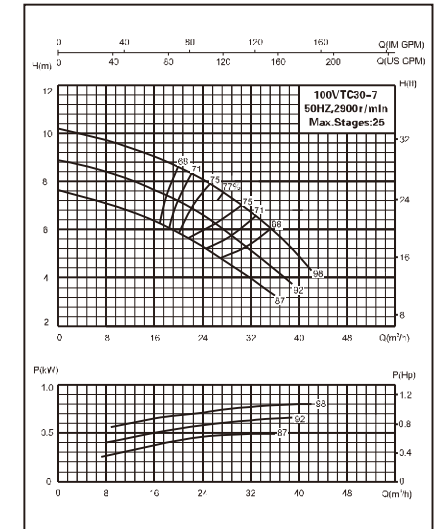
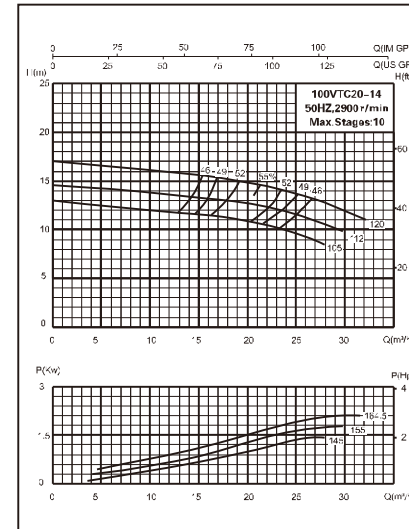

VTC, VTG Pump Curves (Single stage)

VTC, VTG Pump Curves (Single stage)

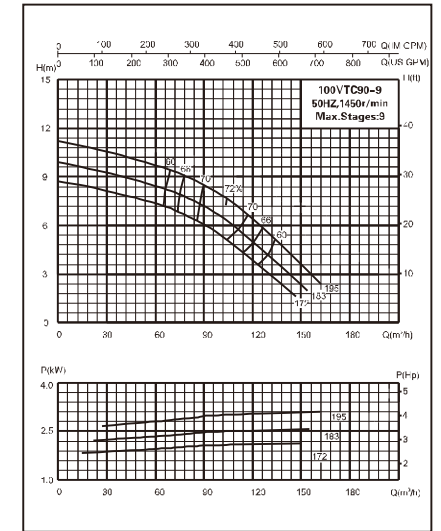
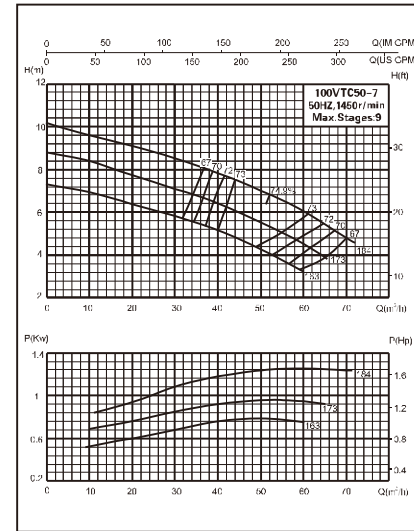
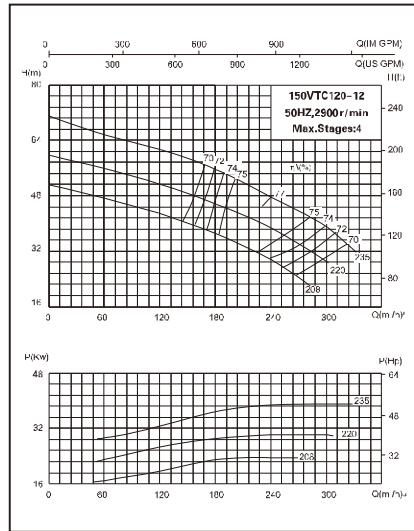
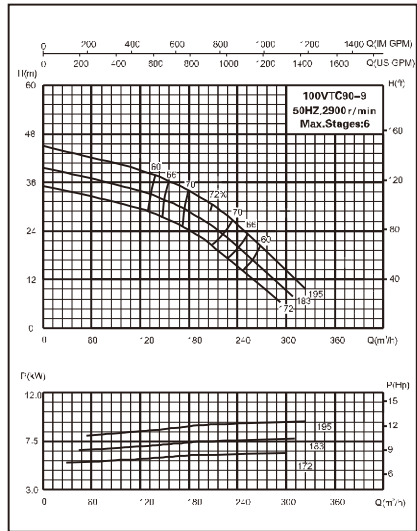
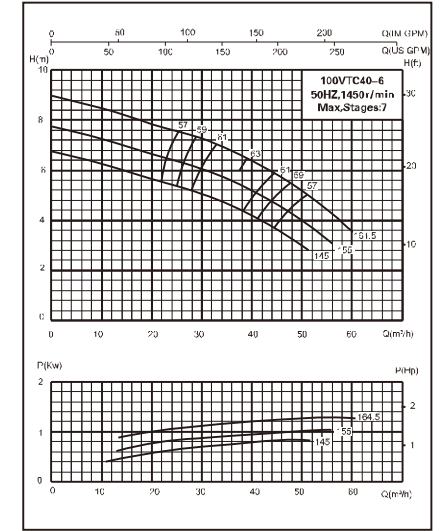
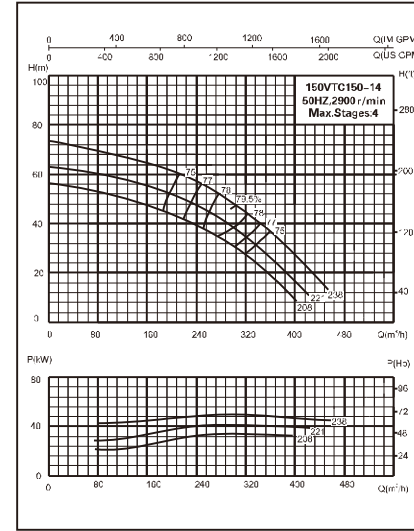
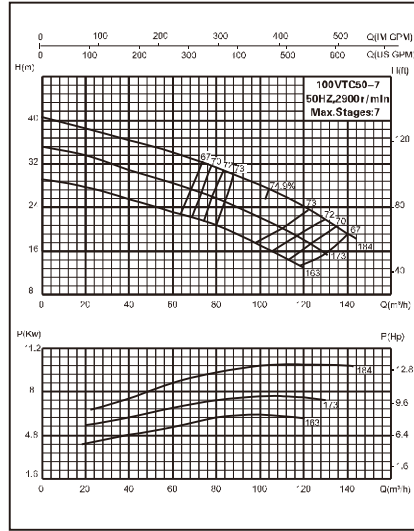
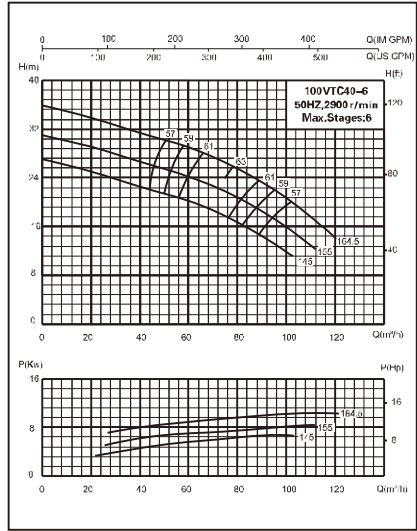

VTC, VTG Pump Curves (Single stage)

VTC, VTG Pump Curves (Single stage)

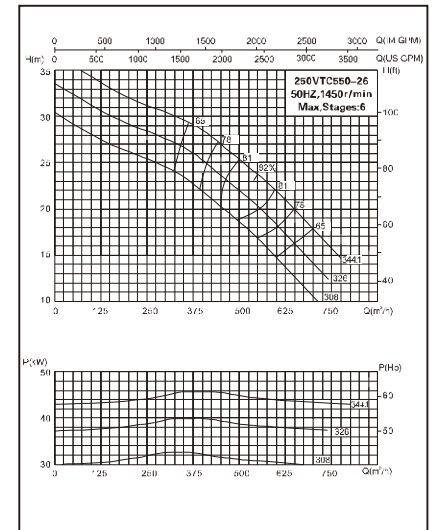
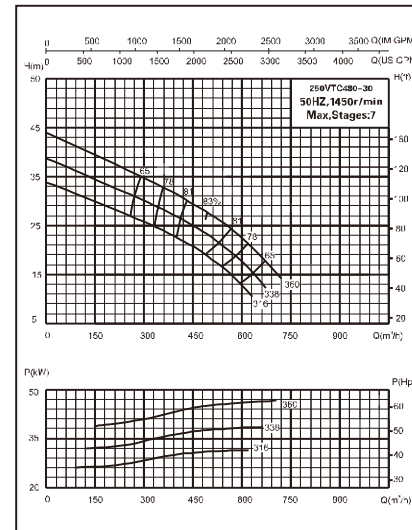
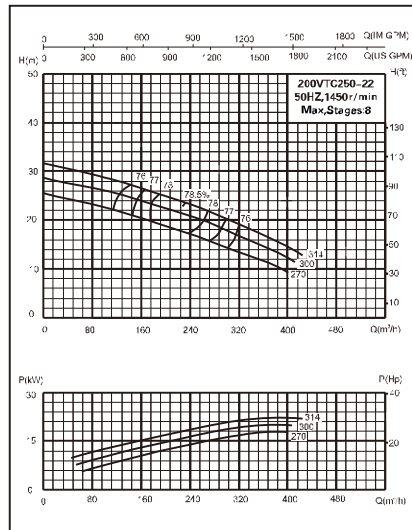
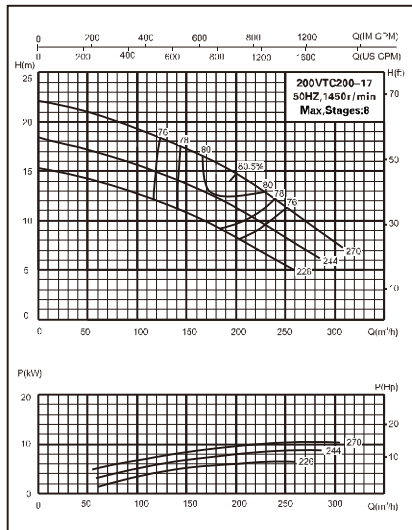
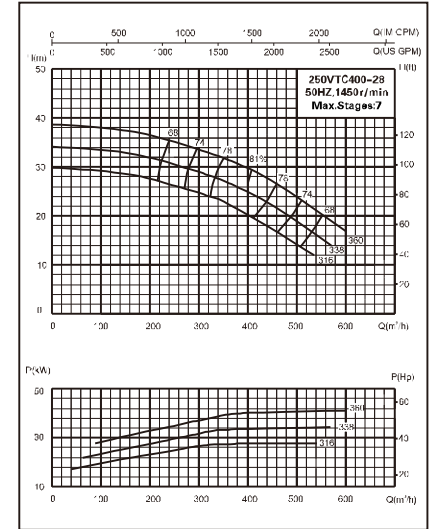
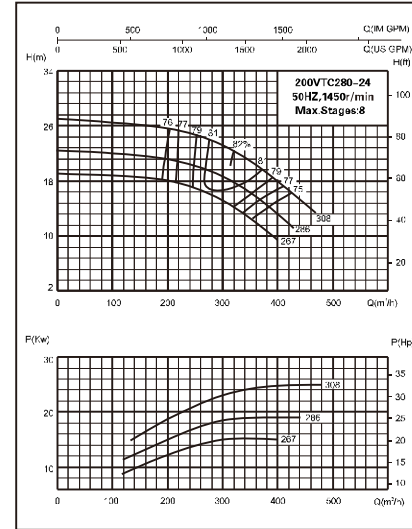
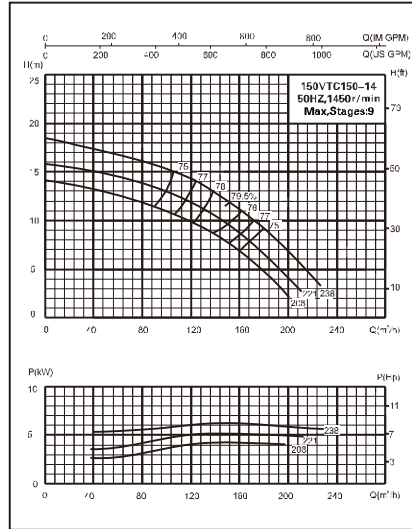
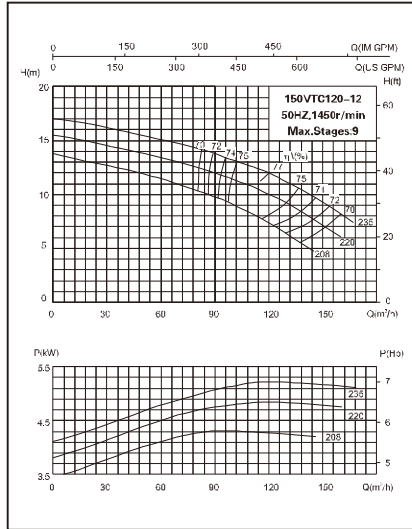

VTC, VTG Pump Curves (Single stage)

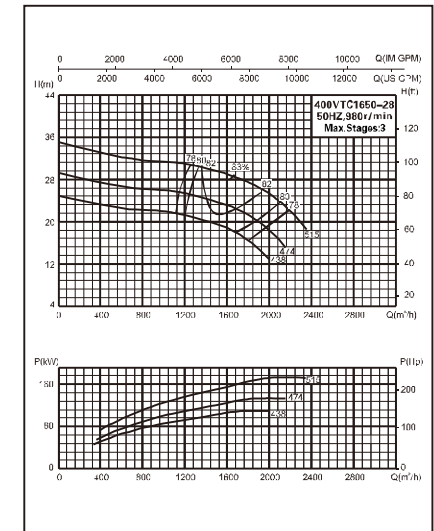
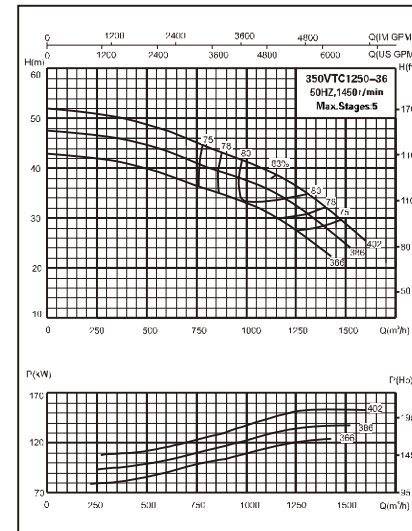
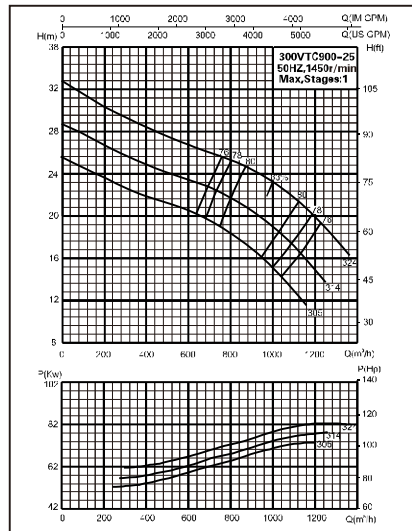
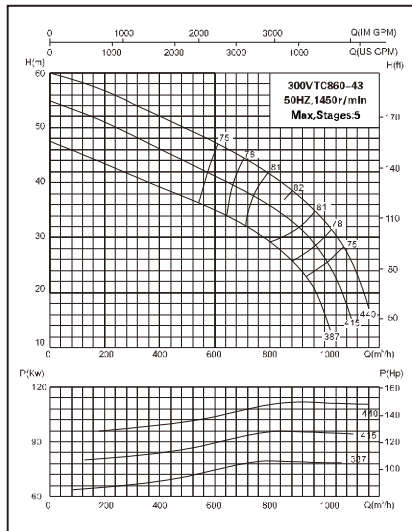
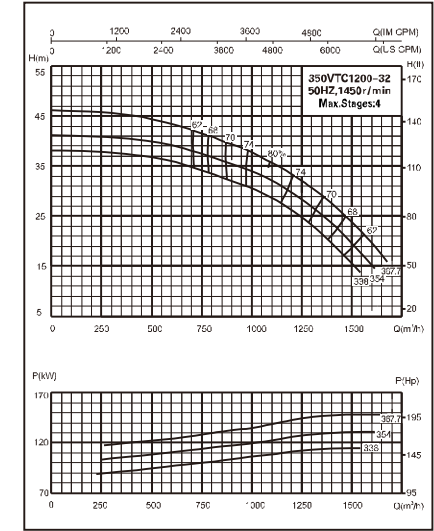
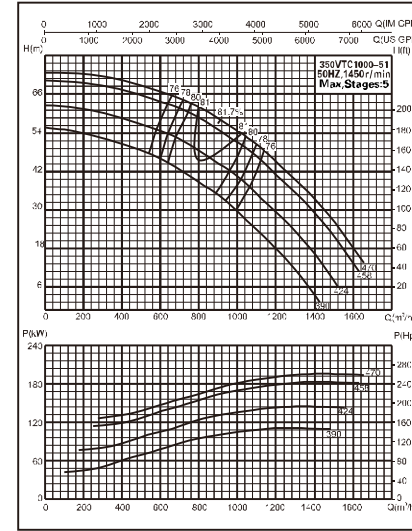
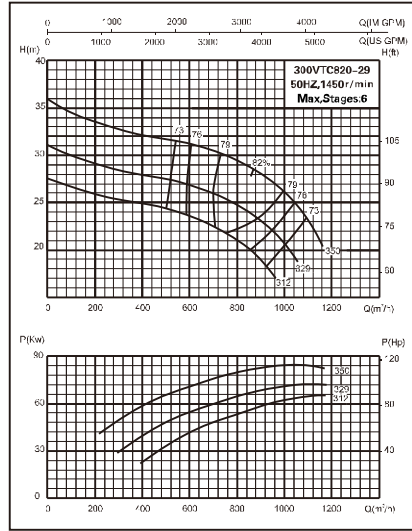
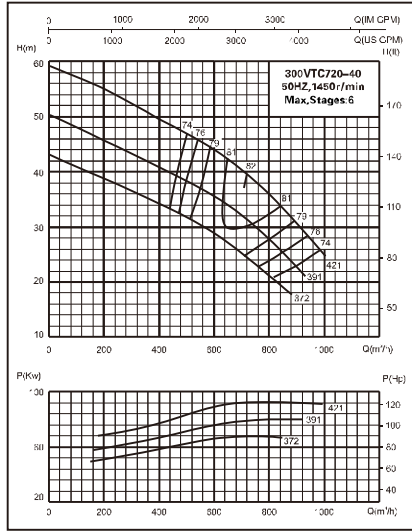

VTC, VTG Pump Curves (Single stage)

VTC, VTG Pump Curves (Single stage)

VTC, VTG Pump Curves (Single stage)

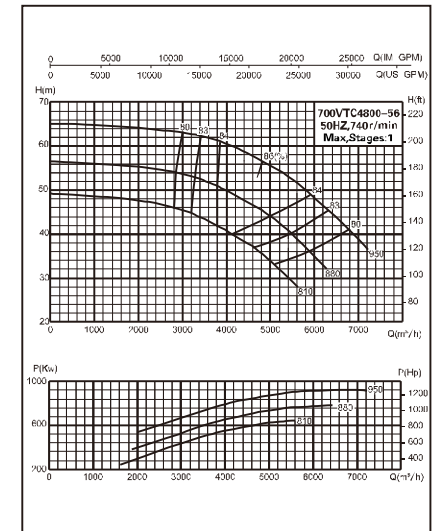
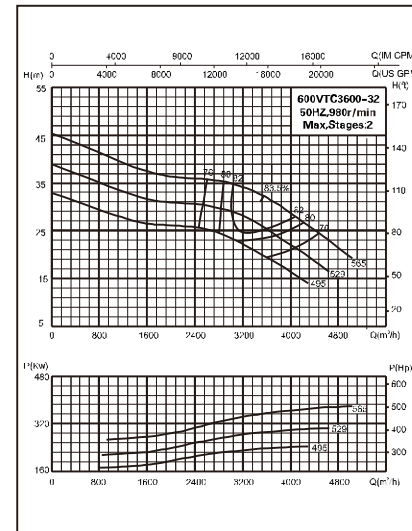
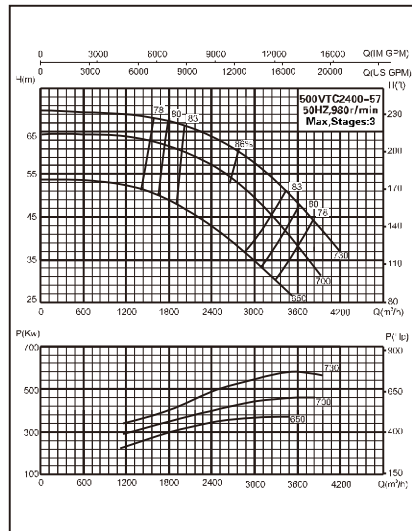
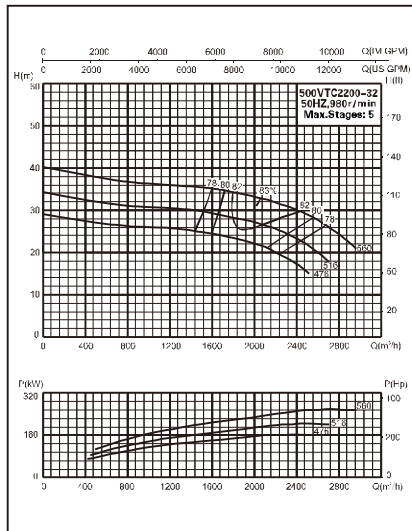
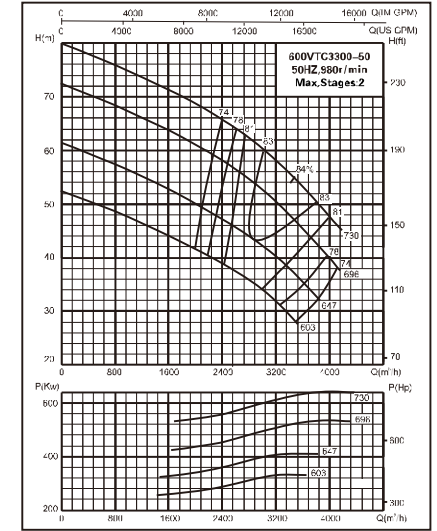
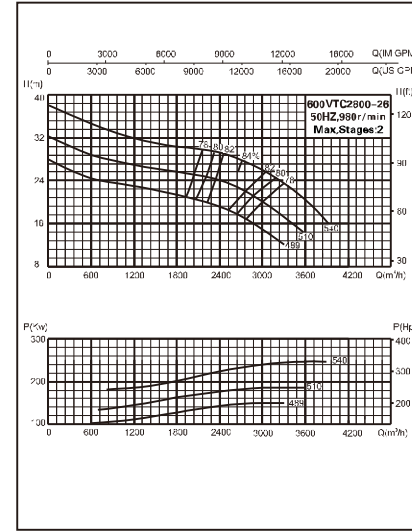
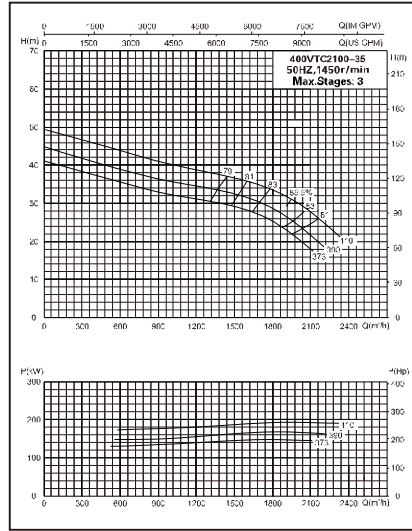
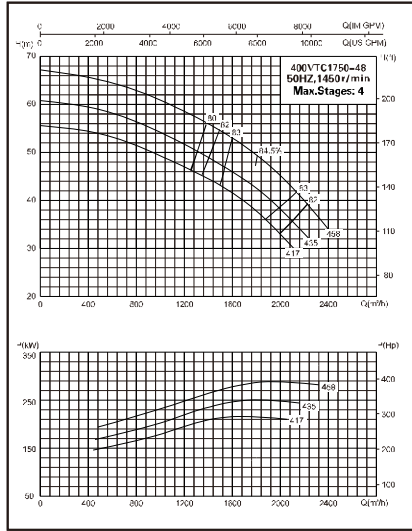

VTM, VTG Vertical Turbine Pumps

Specification range

- Capacities to 40000m³/h (180,000GPM)
- Heads to 60m (200ft)

Design Advantages

1. Fabricated discharge head for all sizes.
2. Seamless flanged ends column pipe and flanges bowl construction incorporating registered fits for ease of assembly during assembly.
3. Alloy construction with external tube flush of critical wear areas available for abrasive services.
4. Available with semi-open or enclosed impeller, with or without wear rings, optimum diffuser and impeller match for maximum efficiency.
5. 416SS shafting. Keyed lineshaft coupling available in all size for ease of maintenance. The lineshaft can be protected by water flushing the enclosing tube bearing on corrosive/abrasive services.
6. Various bearing material available.
7. Wide range of corrosion and erosion resistant materials.
8. Hollow shaft for bowl bearing flushing.
9. Flexible design to accommodate fixed or existing dimensions above and below ground discharge.

Services

- Cooling Water
- Seawater and Raw water intake
- Industrial Process Pumps
- Utility Circulating Water
- Condenser Circulating Water Pumps
- Irrigation and Drainage
- Storm and Flood water
- River Water Intake
- Municipal Water Supply

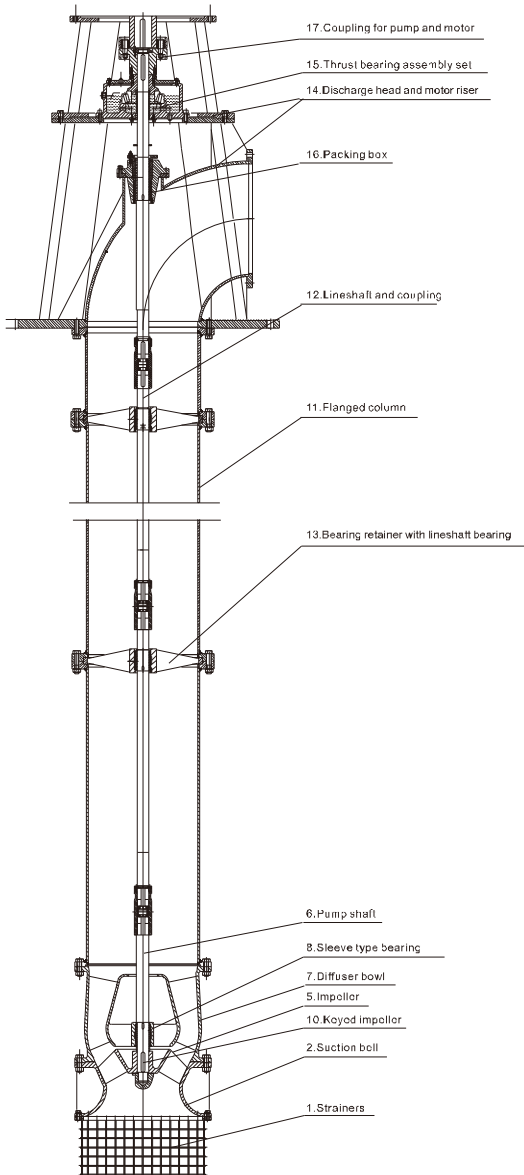

VTM Selection Charts

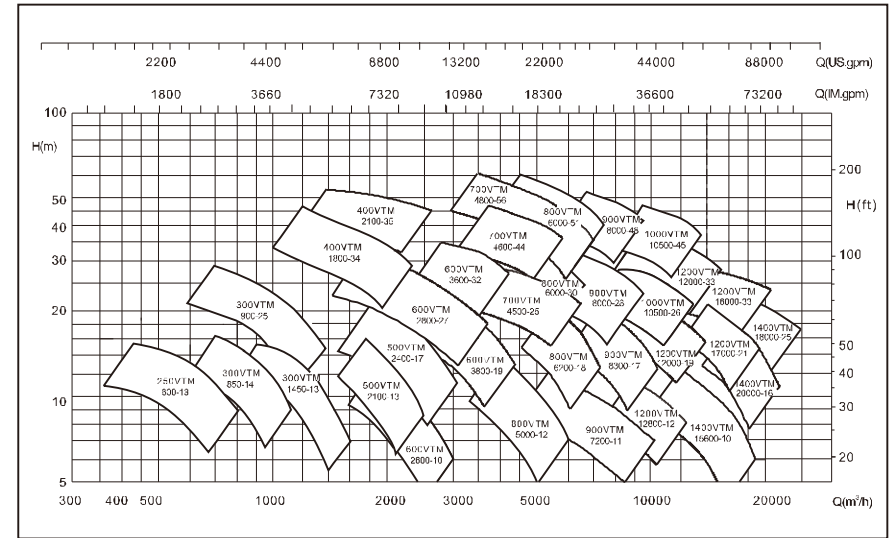

VTM Pump Bowl Assembly Dimensions

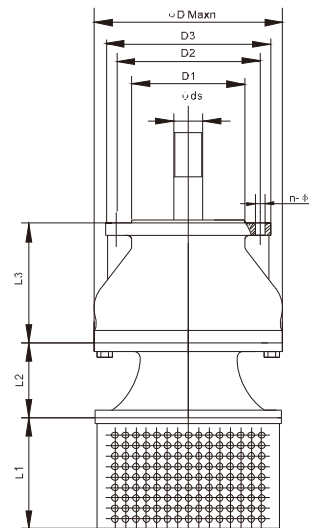

Model	Dmax	L1	L2	L3	φ ds	D1	D2	D3	n-φ d
250VTM600-13	393	320	110	385	40	305h6	350	393	12-φ23
300VTM850-14	427	320	120	415	40	330h6	385	427	12-φ23
300VTM900-25	435	320	180	513	50	320h6	360	400	12-φ23
350VTM1450-13	480	320	240	410	40	395h6	440	480	16-φ23
400VTM1800-34	550	320	230	600	70	440h6	500	550	16-φ25
400VTM2100-35	550	320	230	600	70	440h6	500	550	16-φ25
* 500VTM2100-13	670	320	350	450	50	520h6	620	670	20-φ25
500VTM2400-17	750	320	400	475	60	550h6	600	650	20-φ25
* 600VTM2600-10	745	320	295	530	60	630h6	695	745	20-φ30
600VTM3600-32	740	320	480	620	80	630h6	725	780	20-φ30
600VTM2800-27	710	320	300	735	70	630h6	725	780	20-φ30
* 600VTM3800-19	760	320	330	640	70	630h6	725	780	20-φ30
700VTM4500-25	875	320	570	730	90	730h6	840	895	24-φ30
700VTM4800-44	1075	320	350	925	110	730h6	840	895	24-φ30
700VTM4800-66	1295	320	405	890	120	730h6	840	895	24-φ30
800VTM5000-12	980	320	410	735	80	830h6	950	1010	24-φ34
800VTM6000-51	1165	320	380	1000	120	830h6	950	1010	24-φ34
800VTM6000-30	965	320	625	810	100	830h6	950	1010	24-φ34
800VTM6200-18	990	320	430	835	90	830h6	950	1010	24-φ34
900VTM7200-11	1160	320	490	890	90	930h6	1050	1110	28-φ34
900VTM8000-28	1135	320	960	740	120	930h6	1050	1110	28-φ34
900VTM8300-17	1165	320	515	990	100	930h6	1050	1110	28-φ34
900VTM8000-18	1385	320	450	1190	140	930h6	1050	1110	28-φ34
1000VTM10500-26	1325	320	865	1110	130	1030h6	1160	1220	28-φ41
1000VTM10500-45	1610	320	525	1390	160	1030h6	1160	1220	28-φ41
1000VTM12000-19	1500	320	985	1265	130	1230h6	1380	1450	32-φ41
1000VTM12000-33	1830	320	600	1590	160	1230h6	1380	1450	32-φ41
1200VTM12800-12	1560	320	700	1330	120	1230h6	1380	1450	32-φ41
1200VTM16000-33	1500	320	985	1265	160	1230h6	1380	1450	32-φ41
1200VTM17000-21	1560	320	700	1330	140	1230h6	1380	1450	32-φ41
1400VTM20000-16	1800	320	805	1545	160	1430h6	1590	1675	36-φ48
1400VTM18000-25	1720	320	1130	1450	170	1430h6	1590	1675	36-φ48
1400VTM15600-10	1700	320	750	1340	120	1430h6	1590	1675	36-φ48

* marks the pump using semi-open impeller.

VTM, VTG Pump Dimensions (Above Ground Discharge)

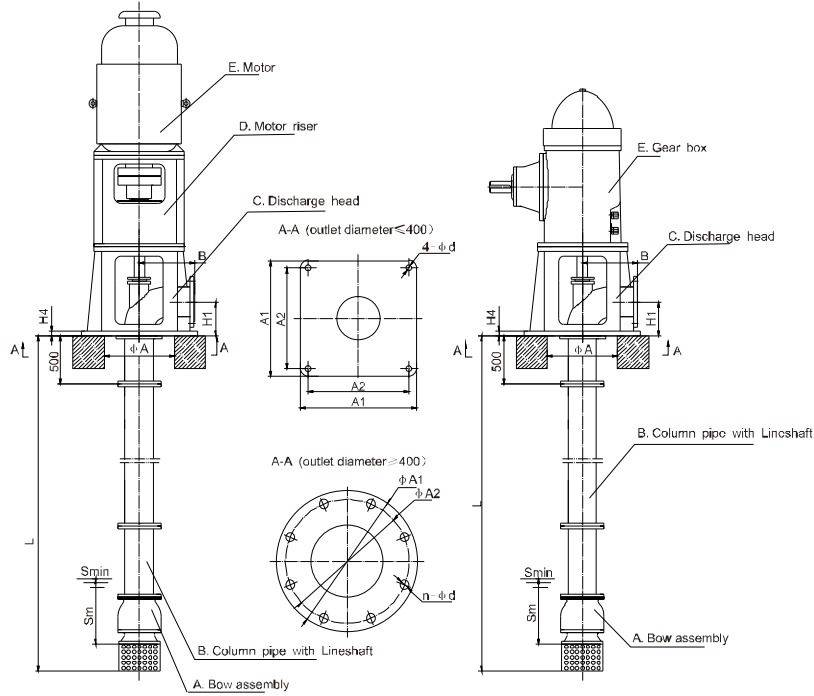

Model	$\phi A1$	$\phi A2$	A1	A2	n- ϕd	H1	H4	B	Sm	ϕA
250VTM	/	/	780	720	4- $\phi 30$	265	30	450	700	500
300VTM	/	/	880	820	4- $\phi 30$	320	35	500	900	600
300VTM	/	/	930	870	4- $\phi 30$	370	35	550	1400	650
400VTM	/	/	1030	960	4- $\phi 30$	420	40	600	1800	800
500VTM	1400	1300	/	/	8- $\phi 40$	520	40	700	1800	900
600VTM	1500	1400	/	/	8- $\phi 40$	620	45	850	2000	1000
700VTM	1600	1500	/	/	12- $\phi 40$	700	50	950	2200	1100
800VTM	1700	1600	/	/	16- $\phi 40$	800	50	1000	2400	1200
900VTM	1800	1700	/	/	16- $\phi 40$	900	60	1050	2400	1300
1000VTM	1900	1800	/	/	16- $\phi 45$	1000	60	1100	2600	1400
1200VTM	2000	1900	/	/	16- $\phi 50$	1200	65	1150	2800	1500
1400VTM	2300	2200	/	/	16- $\phi 50$	1400	70	1450	3000	1700

1. Discharge Flanges drilled to ISO, DIN, BS or ANSI.
2. The final installation size will be subject to the final overall dimension of CNP.
3. 500 outlet diameter and below can directly use the table size, over 600 will be cancelled the strainer.
4. We recommend below ground discharge when the outlet diameter is more than 1200

VTM, VTG Pump Dimensions (Below Ground Discharge)

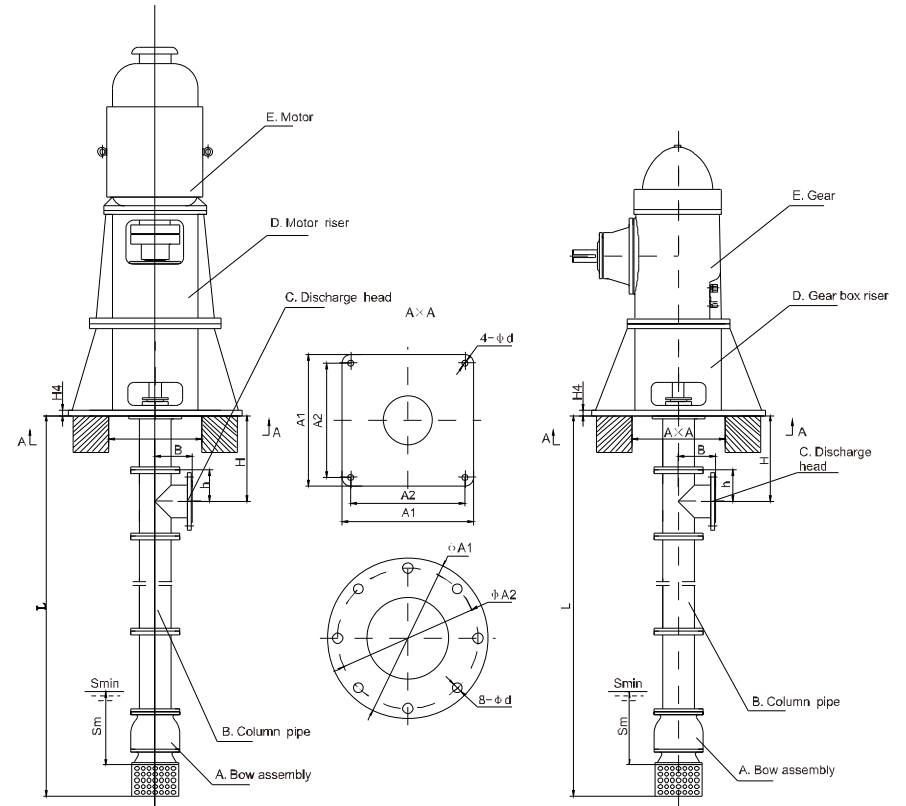

Model	$\phi A1$	$\phi A2$	A1	A2	ϕd	H	B	Sm	A×A
250VTM	/	/	780	720	30	200	280	450	550×550
300VTM	/	/	880	820	30	230	330	500	650×650
350VTM	/	/	930	870	30	260	380	600	700×700
400VTM	/	/	1030	960	30	290	430	700	750×750
500VTM	/	/	1230	1160	33	350	540	900	1000×1000
600VTM	/	/	1380	1310	33	420	640	1000	1000×1000
700VTM	1500	1400	/	/	36	700	800	1200	1800×1800
800VTM	1650	1550	/	/	36	800	900	1400	200×2000
900VTM	1800	1700	/	/	36	900	1000	1600	2200×2200
1000VTM	1950	1850	/	/	42	1000	1100	1800	2400×2400
1200VTM	2250	2150	/	/	42	1200	1200	2200	2600×2600
1400VTM	2550	2450	/	/	42	1400	1400	2600	3000×3000

According to customer requirement: Discharge flanges drilled to ISODIN, BS or ANSI standard.

VTM, VTG Pump Curves

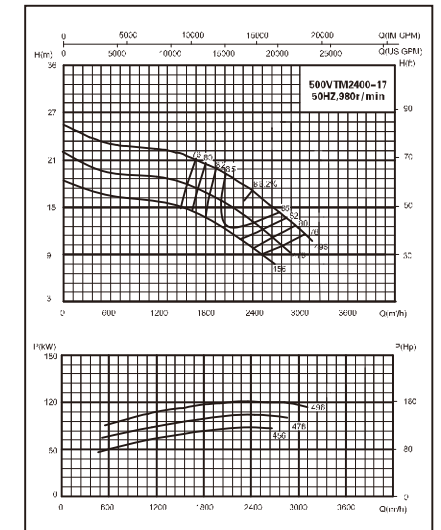
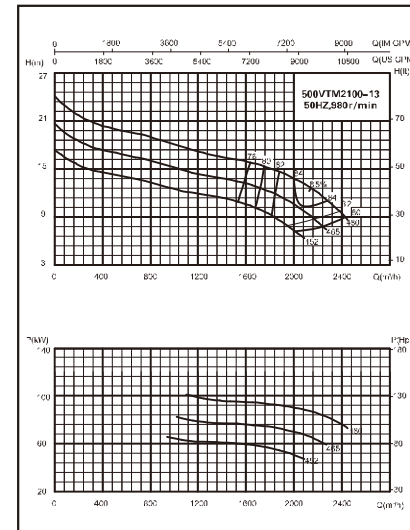
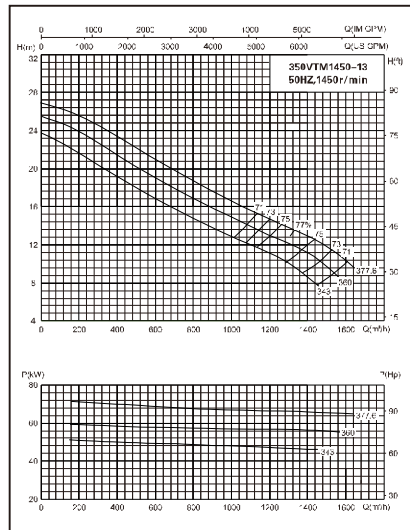
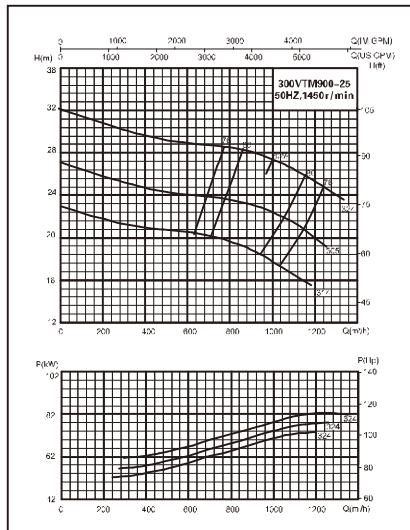
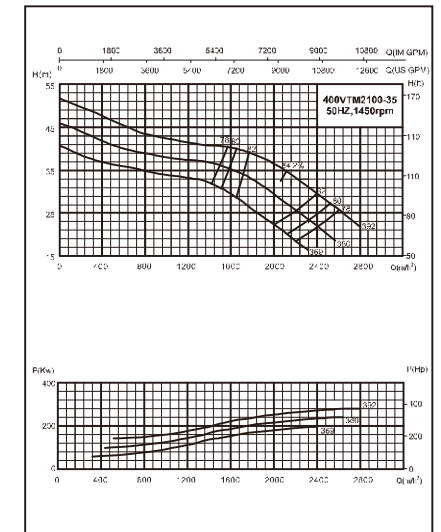
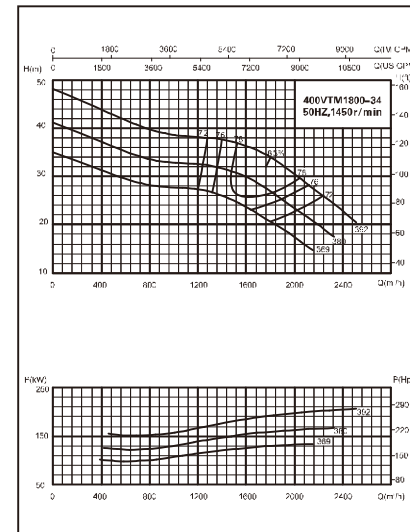
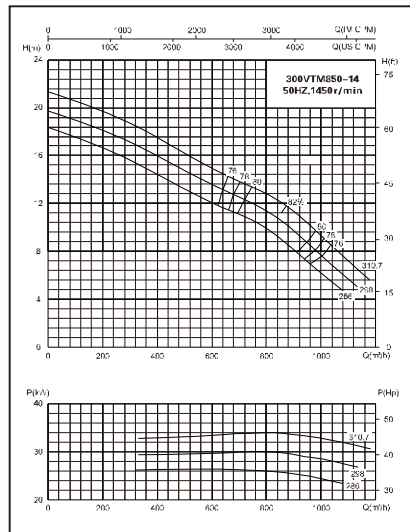
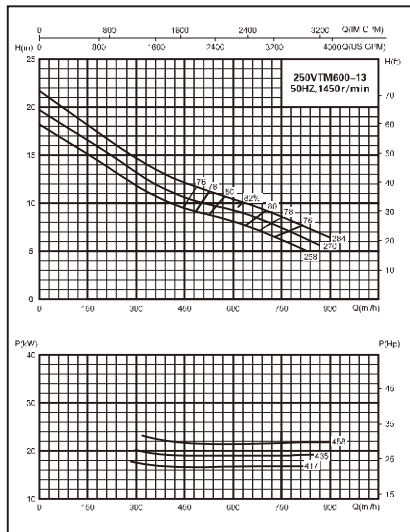

VTM, VTG Pump Curves

VTM, VTG Pump Curves

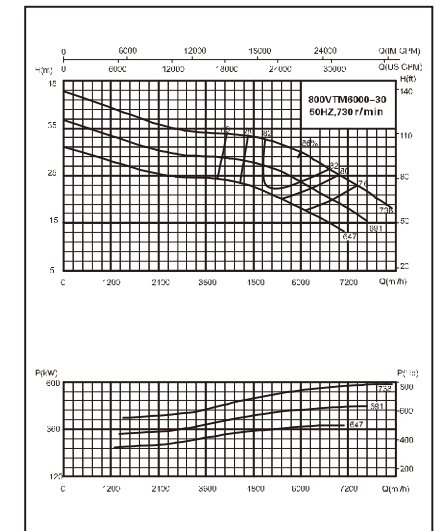
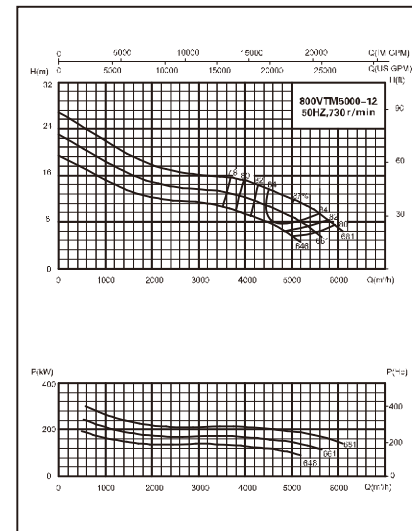
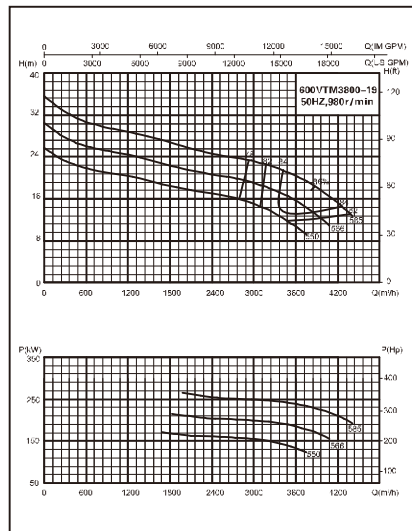
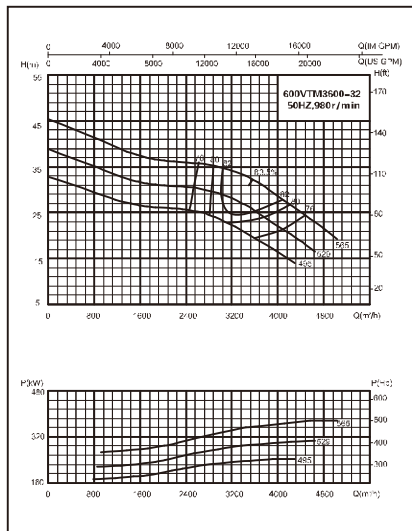
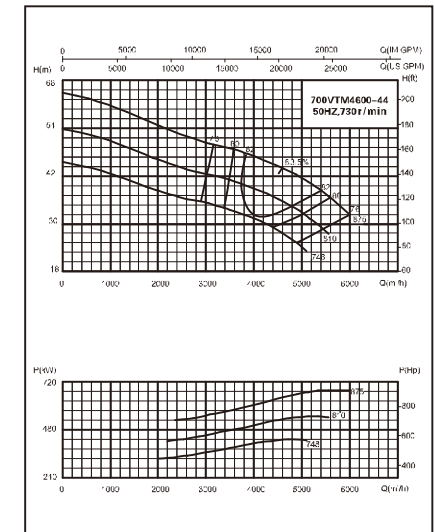
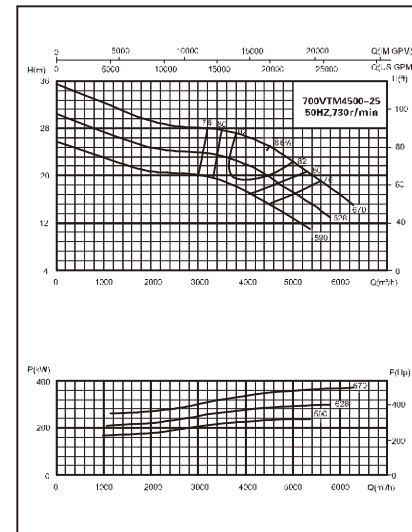
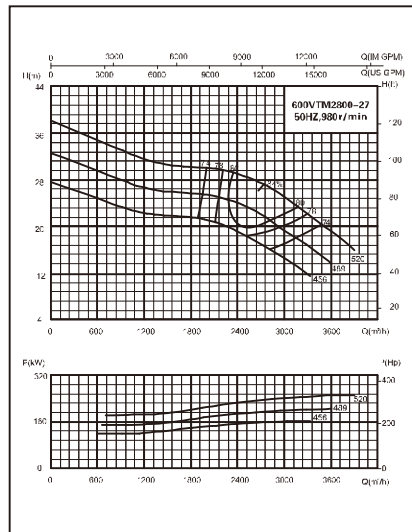
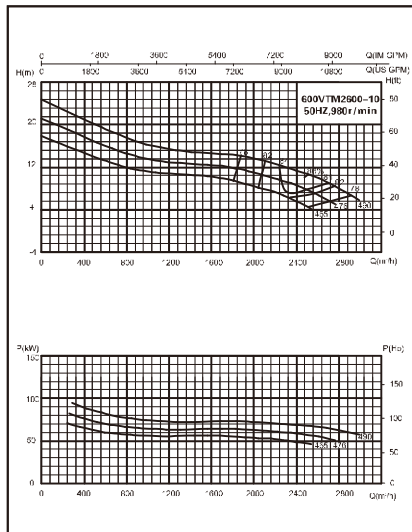

VTM, VTG Pump Curves

VTM, VTG Pump Curves

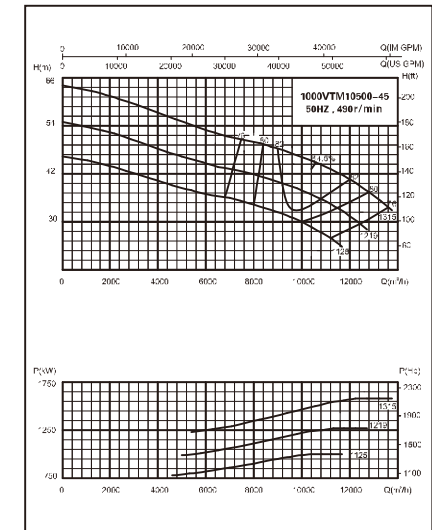
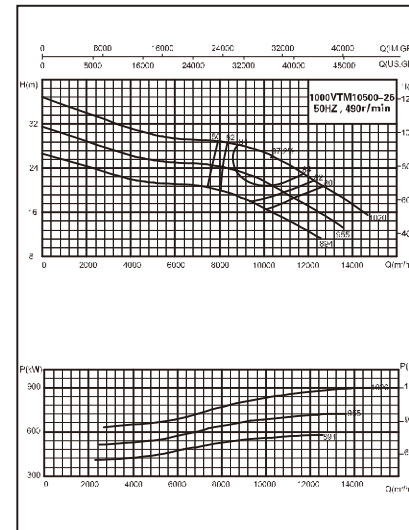
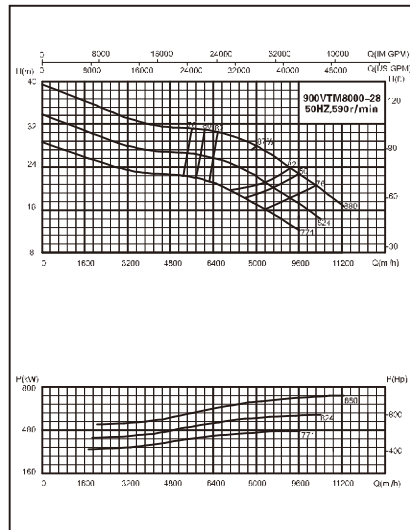
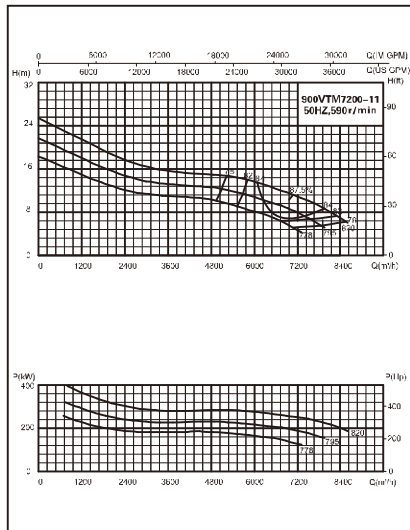
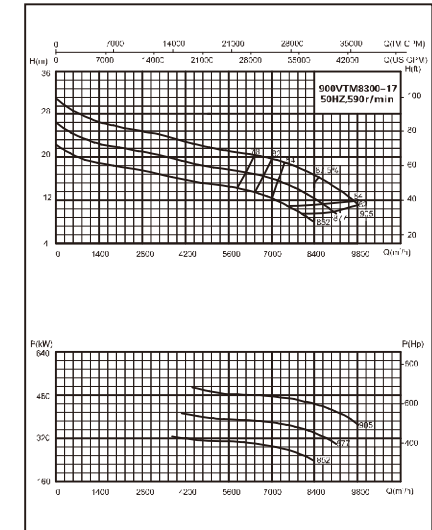
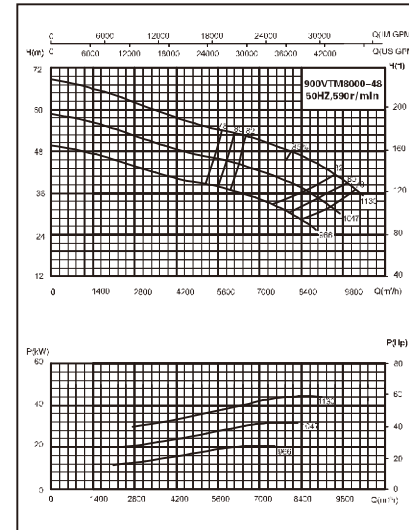
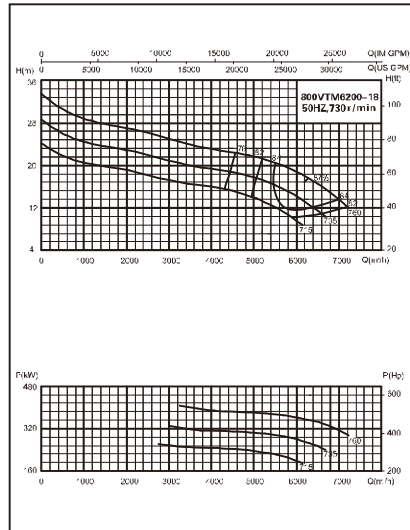
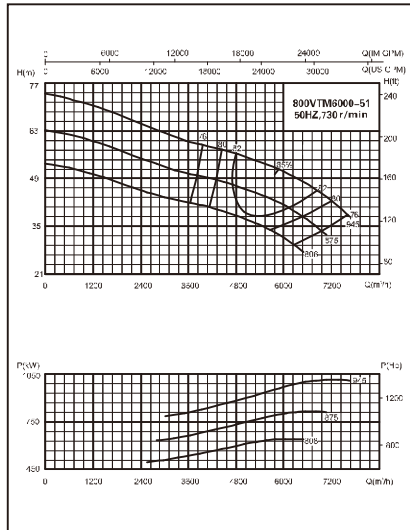

VTM, VTG Pump Curves

VTM, VTG Pump Curves

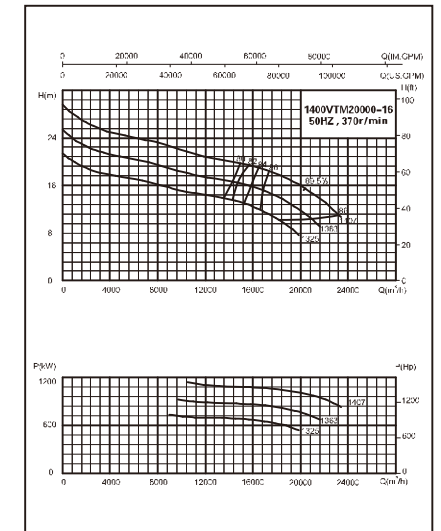
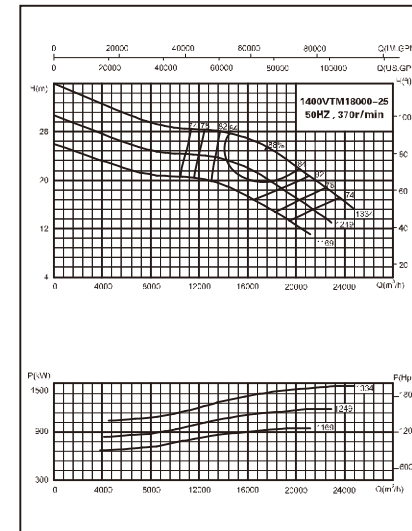
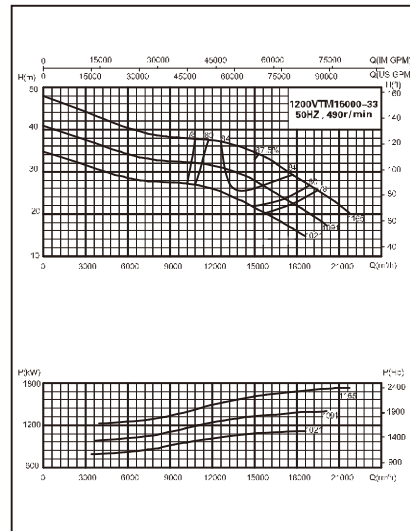
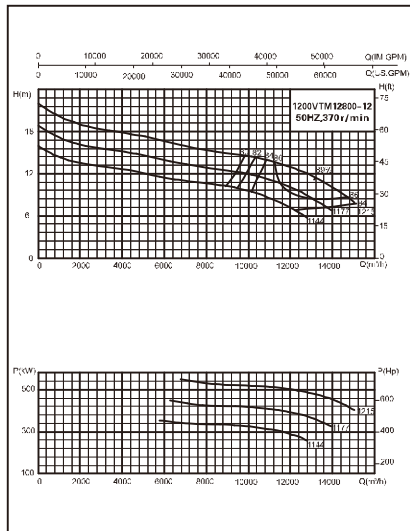
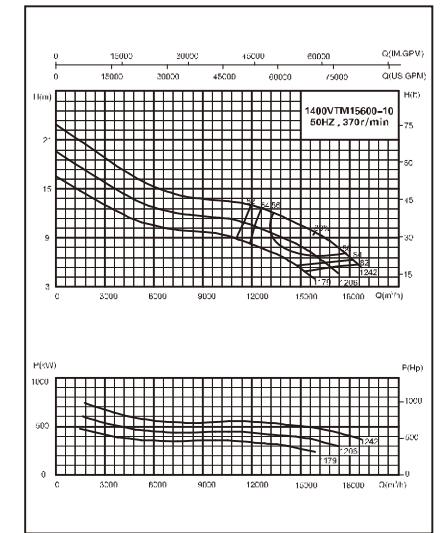
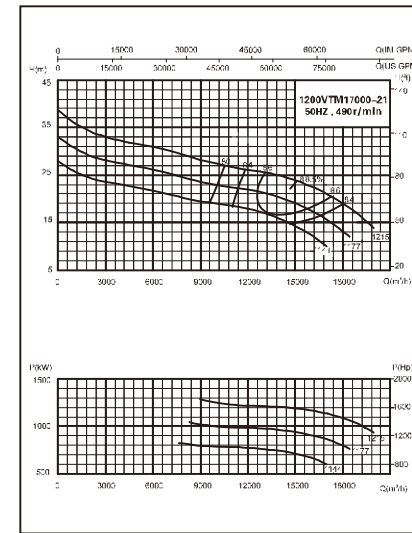
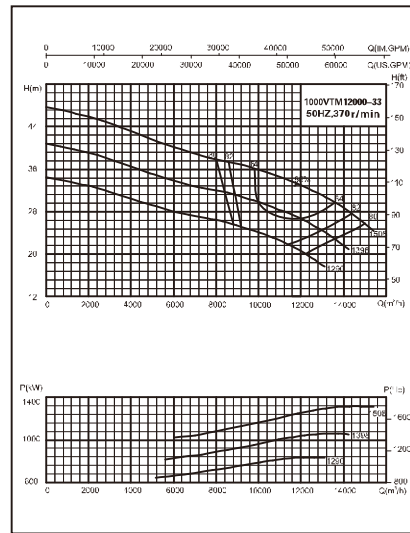
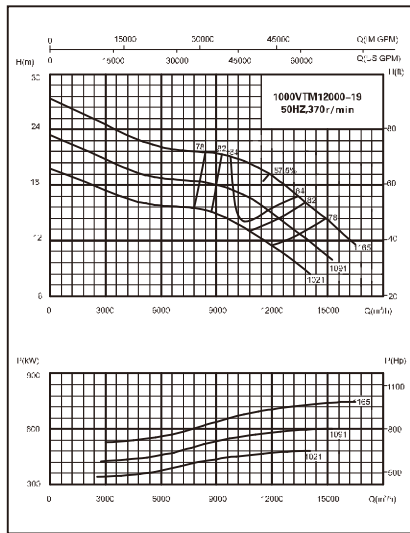

VTM, VTG Pump Curves

VTA, VTG Vertical Turbine Pumps

Specification range

- Capacities to 50000 m³/h (220000GPM)
- Heads to 15 m (50ft)

Design Advantages

1. Fabricated discharge head for all sizes.
2. Seamless flanged ends column pipe and flanges bowl construction incorporating registered fits for ease of assembly during assembly.
3. Alloy construction with external tube flush of critical wear areas available for abrasive services.
4. High efficiency design. Broad hydraulic coverage provides best selection to meet specific operating conditions.
5. 416SS shafting. Keyed lineshaft coupling available in all size for ease of maintenance. The lineshaft can be protected by water flushing the enclosing tube bearing on corrosive/abrasive services.
6. Various bearing material available.
7. Wide range of corrosion and erosion resistant materials.
8. Flexible design to accommodate fixed or existing dimensions.

Services

- Pollution Control
- Medium and Low Head Circulation
- Effluent Disposal
- Flood Control
- Dewatering
- River Water Intake
- Cooling Water
- Irrigation and Drainage
- Dry Docks

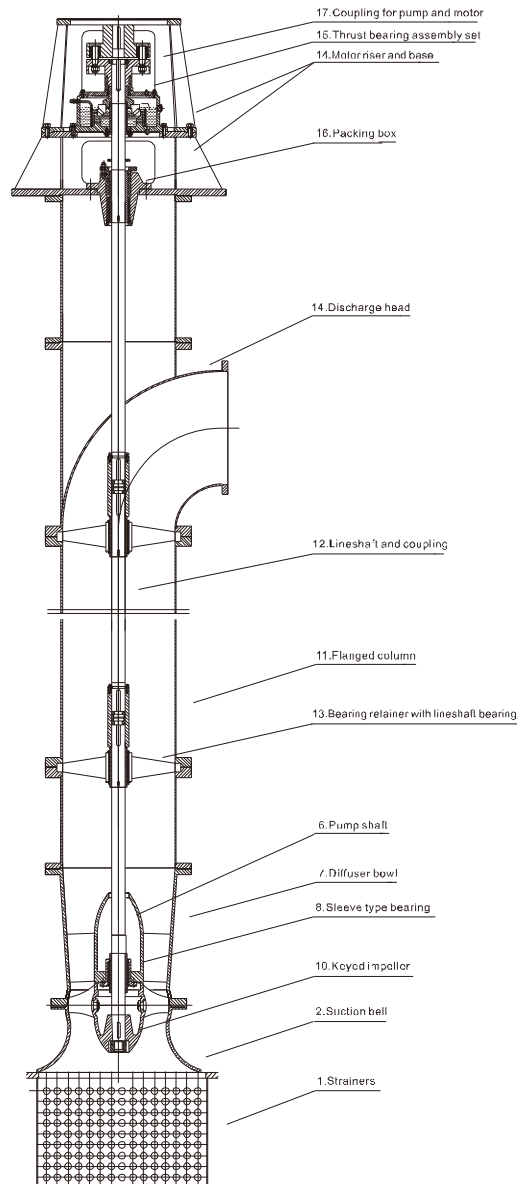

Selection Charts of VTA pumps

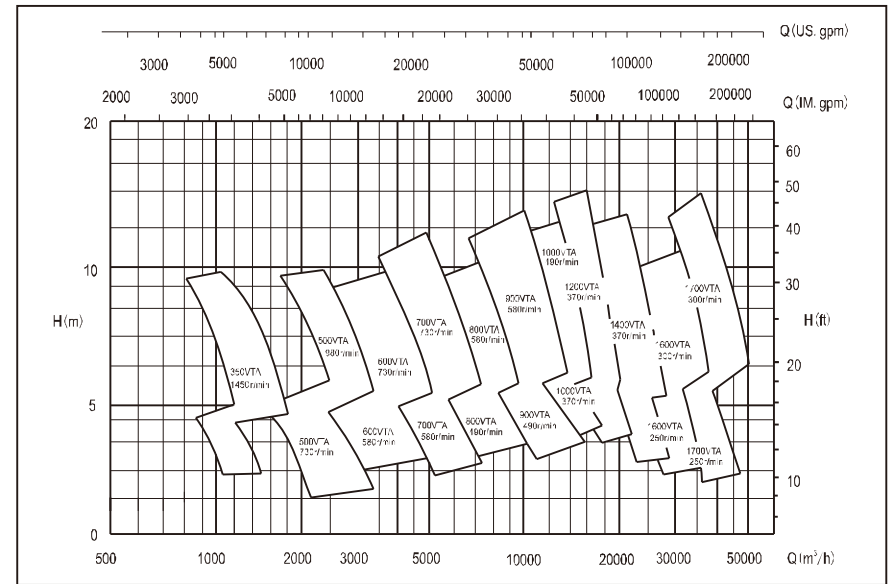

VTA Pump Bowl Assembly Dimensions

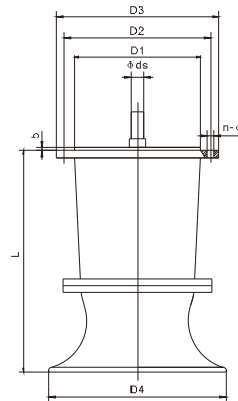

Model	Impeller Dia	D1	D2	D3	D4	L	phi ds	b	n-phi d
350VTA	300	370h6-h7	415	450	516	590	40	5	8-phi 18
500VTA	450	520h6-h7	600	650	700	900	60	5	12-phi 23
600VTA	550	620h6-h7	700	760	850	950	75	6	16-phi 23
700VTA	650	720h6-h7	810	865	1000	1000	90	7	20-phi 25
800VTA	750	820h6-h7	910	970	1120	1100	100	8	24-phi 25
900VTA	850	920h6-h7	1020	1080	1280	1150	110	8	24-phi 30
1000VTA	950	1020h6-h7	1120	1180	1400	1200	120	10	28-phi 30
1200VTA	1100	1270h6-h7	1380	1450	1600	1300	140	10	32-phi 30
1400VTA	1300	1420h6-h7	1530	1600	1750	1400	160	10	36-phi 30
1600VTA	1500	1620h6-h7	1630	1700	1900	1500	180	10	40-phi 30
1700VTA	1600	1720h6-h7	1830	1900	2150	1600	190	10	40-phi 30

VTA, VTG Pump Dimensions (Above Ground Discharge)

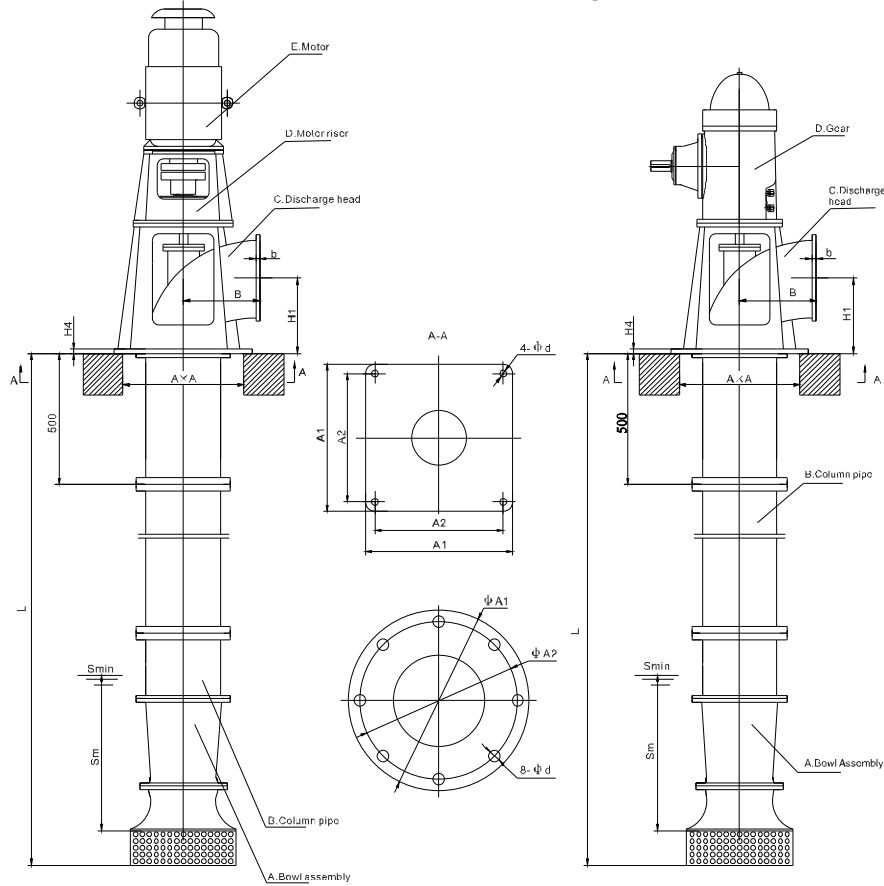

Model	φA1	φA2	A1	A2	φd	H1	H4	B	Smin	φA
350VTA	/	/	930	870	30	370	35	550	600	550
500VTA	/	/	1230	1160	33	520	40	700	900	750
600VTA	1800	1700	/	/	36	600	45	750	1000	850
700VTA	1500	1400	/	/	36	700	50	850	1200	950
800VTA	1800	1700	/	/	36	800	55	1050	1400	1100
900VTA	1800	1700	/	/	36	900	60	1050	1600	1200
1000VTA	1950	1850	/	/	42	1000	60	1150	1800	1300
1200VTA	2250	2150	/	/	42	1200	60	1250	2200	1600
1400VTA	2550	2450	/	/	42	1400	60	1450	2600	1800
1600VTA	3150	3050	/	/	46	1600	60	1750	2800	2000
1700VTA	3200	3100	/	/	46	1700	60	1750	3000	2200

According to customer requirement: Discharge flanges drilled to ISODIN, BS or ANSI stanard.

VTA, VTG Pump Dimensions (Below Ground Discharge)

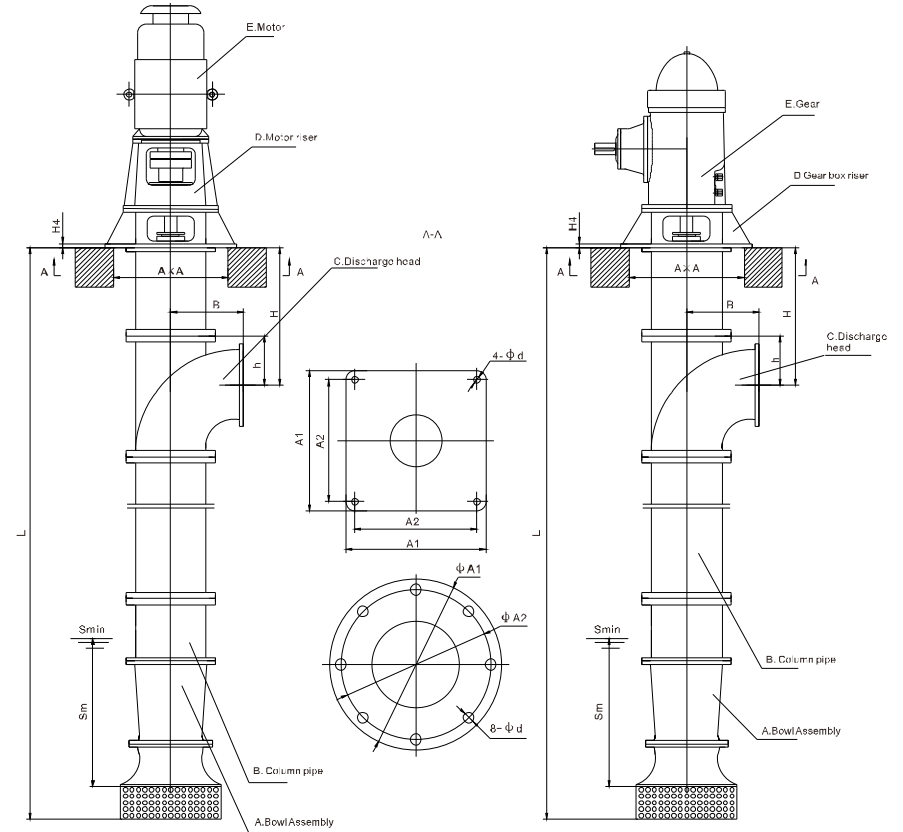

Model	φA1	φA2	A1	A2	φd	H	B	Smin	A x A
350VTA	/	/	930	870	30	370	550	600	700 x 700
500VTA	/	/	1230	1160	33	520	700	900	1000 x 1000
600VTA	1800	1700	/	/	36	600	750	1000	1300 x 1300
700VTA	1500	1400	/	/	36	700	850	1200	1800 x 1800
800VTA	1800	1700	/	/	36	800	1050	1400	2000 x 2000
900VTA	1800	1700	/	/	36	900	1050	1600	2200 x 2200
1000VTA	1950	1850	/	/	42	1000	1150	1800	2400 x 2400
1200VTA	2250	2150	/	/	42	1200	1250	2200	2600 x 2600
1400VTA	2550	2450	/	/	42	1400	1450	2600	3000 x 3000
1600VTA	3150	3050	/	/	46	1600	1750	2800	3200 x 3200
1700VTA	3200	3100	/	/	46	1700	1750	3000	3500 x 3500

According to customer requirement: Discharge flanges drilled to ISODIN, BS or ANSI stanard.

VTA,VTG Pump Curves

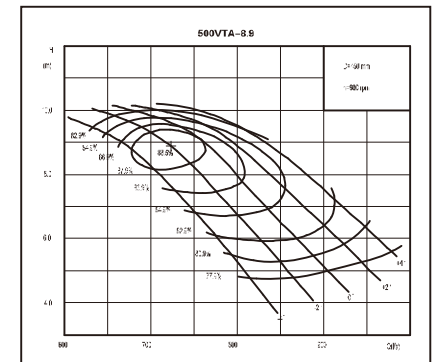
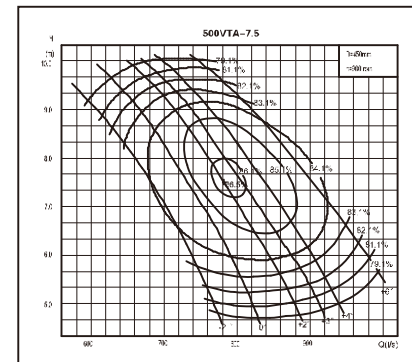
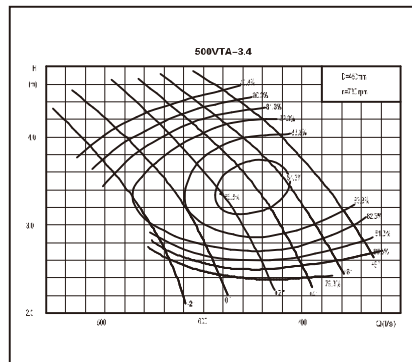
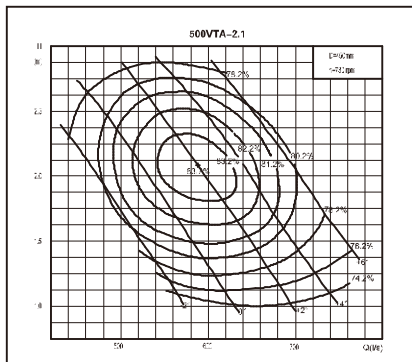
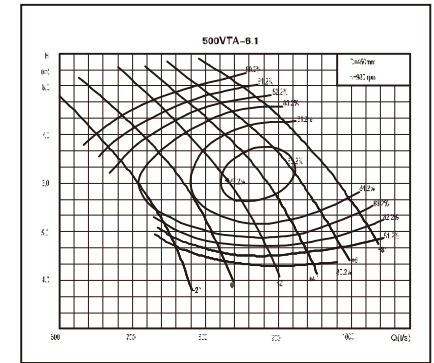
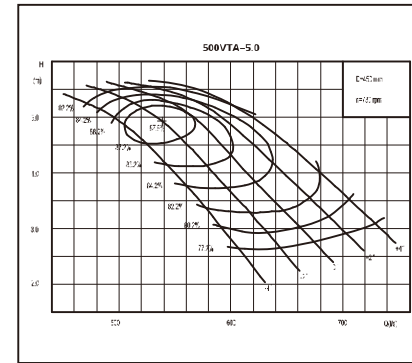
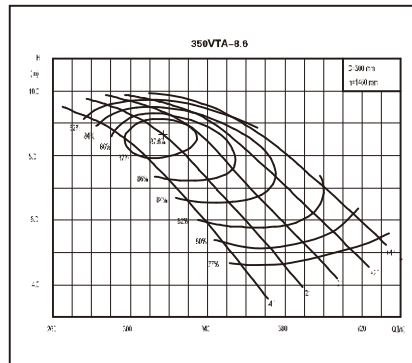
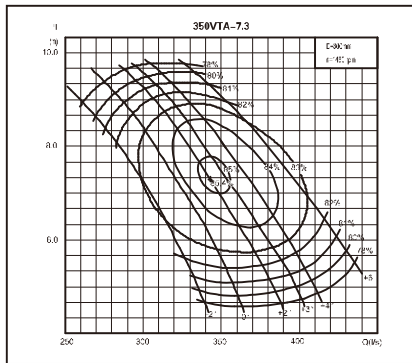
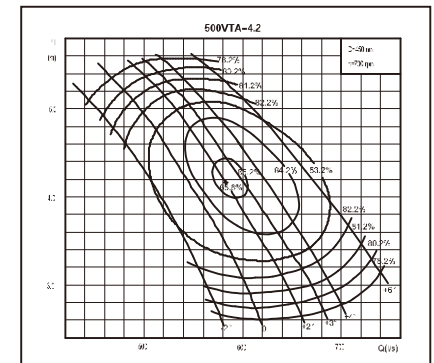
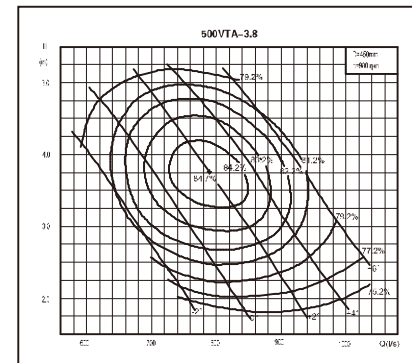
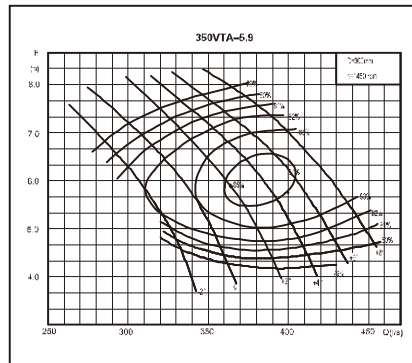
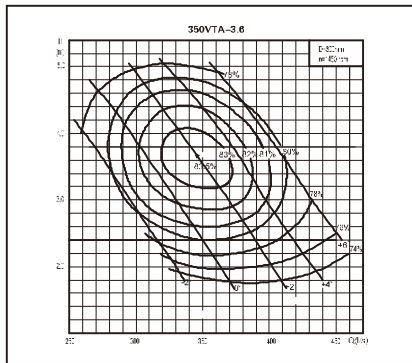

VTA,VTG Pump Curves

VTA,VTG Pump Curves

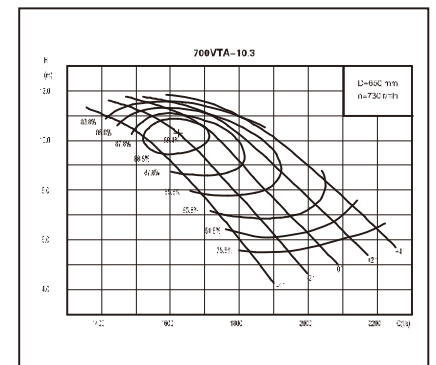
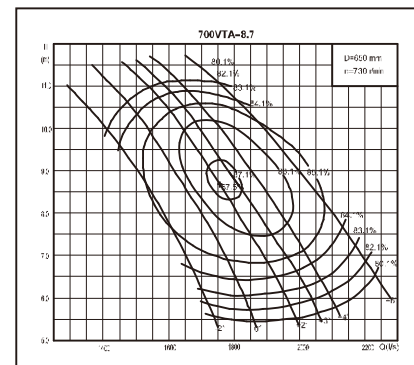
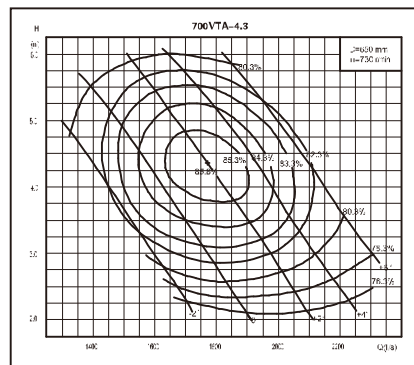
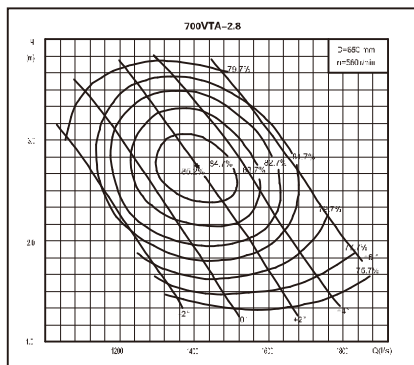
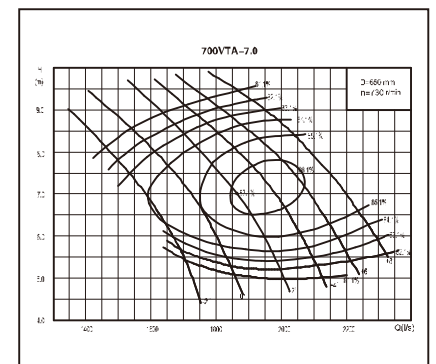
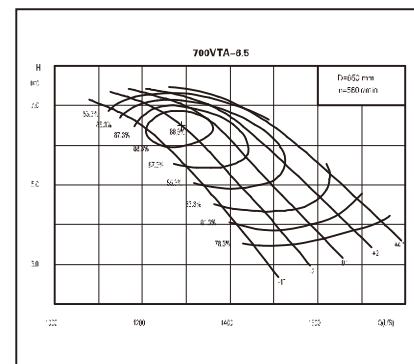
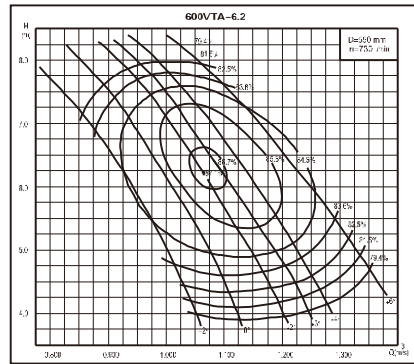
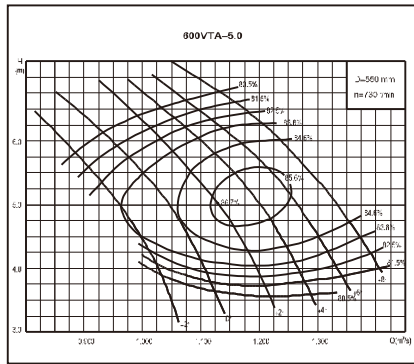
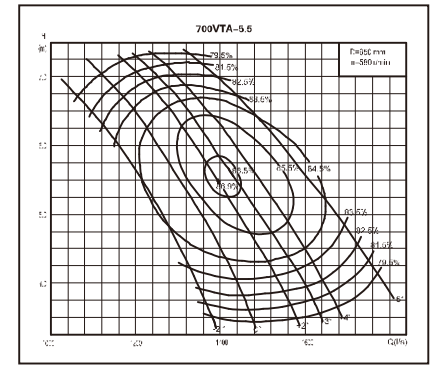
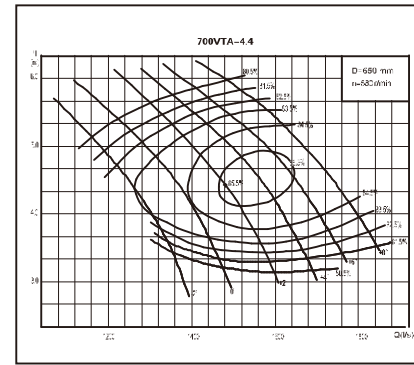
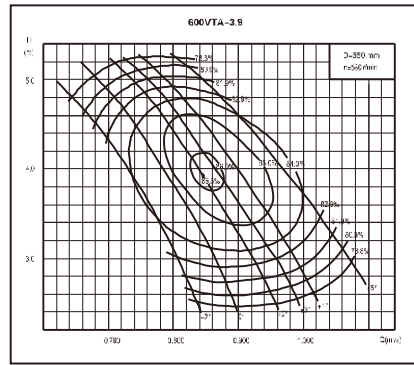
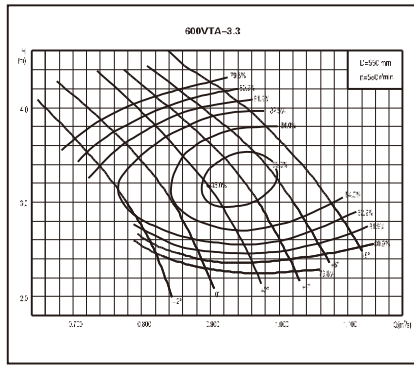

VTA,VTG Pump Curves

VTA,VTG Pump Curves

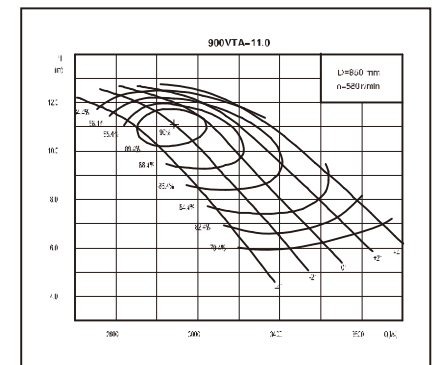
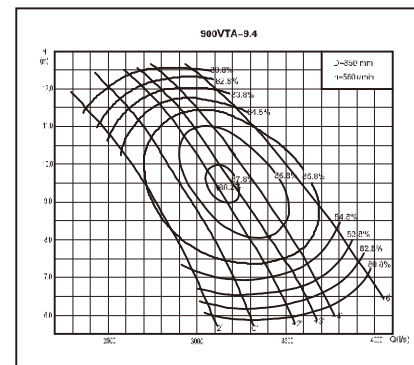
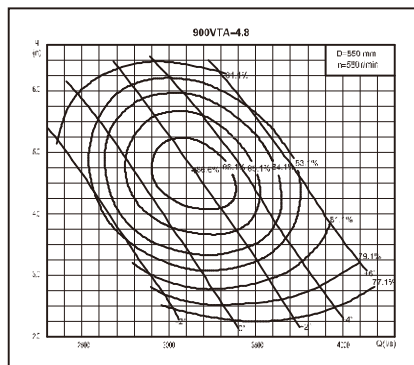
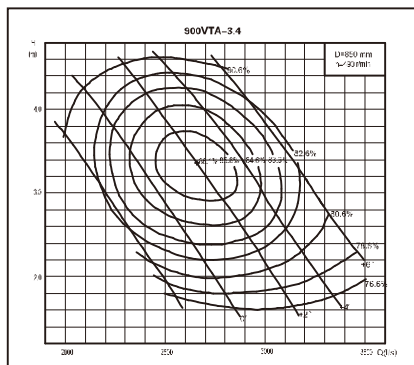
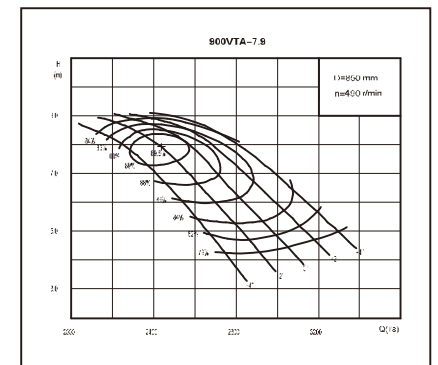
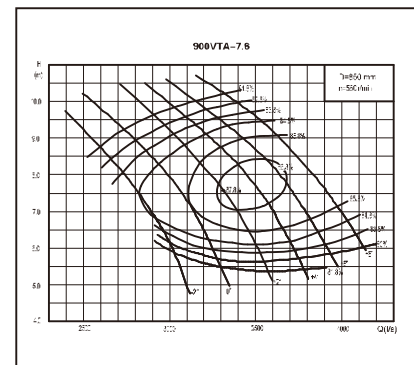
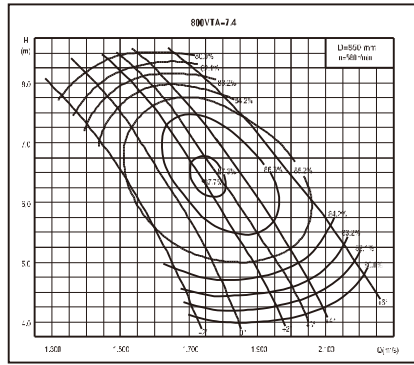
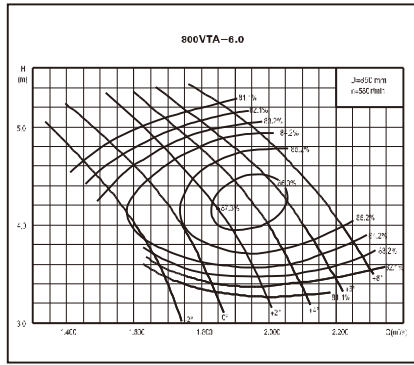
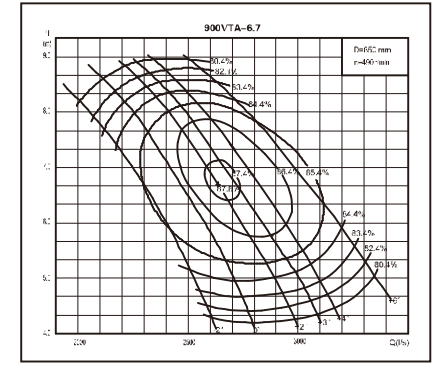
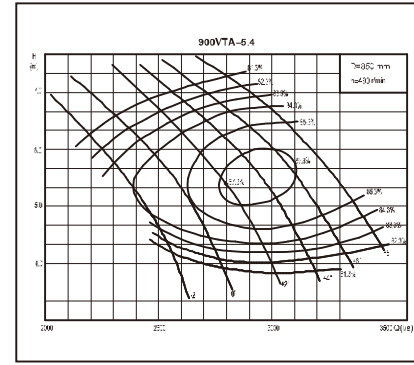
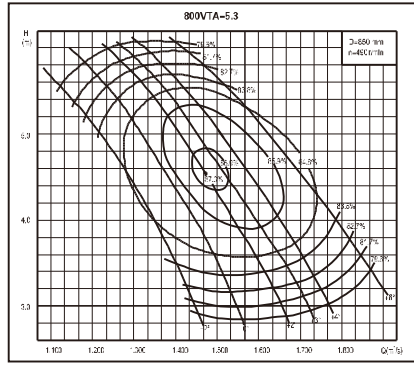
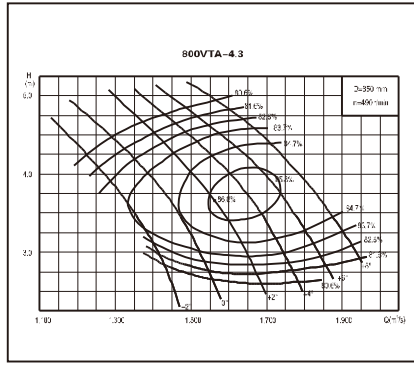

VTA,VTG Pump Curves

VTA,VTG Pump Curves

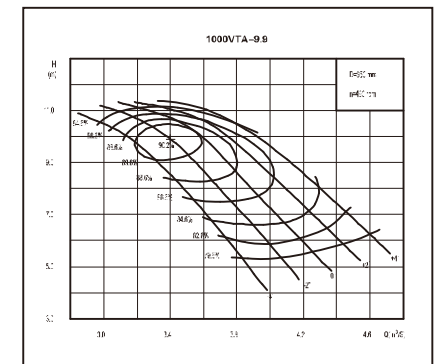
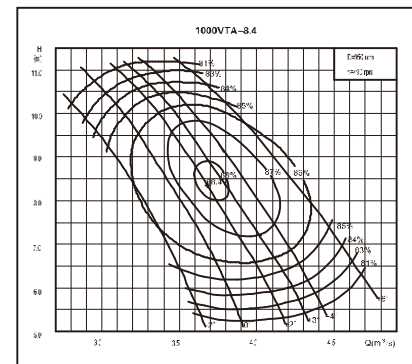
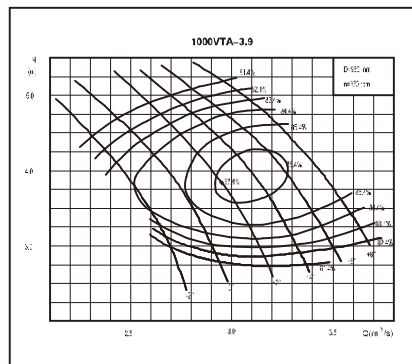
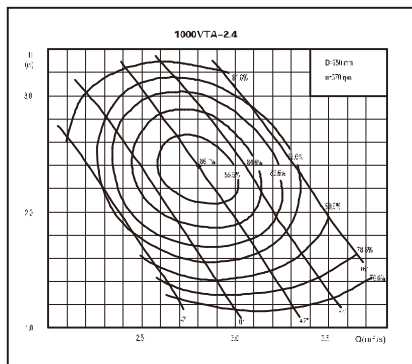
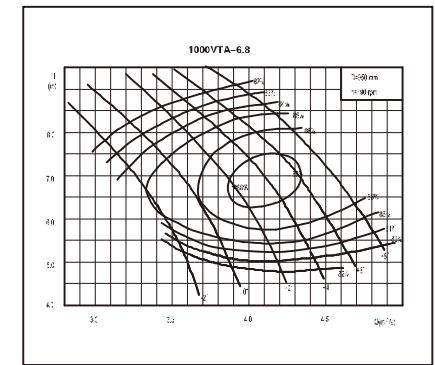
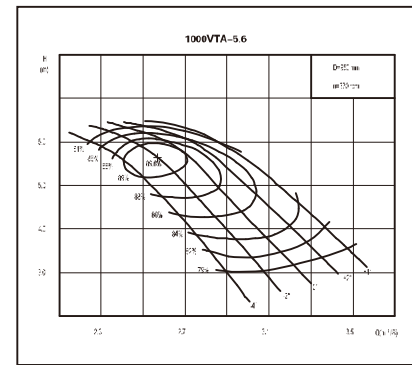
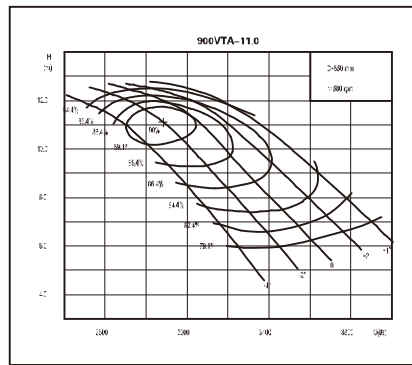
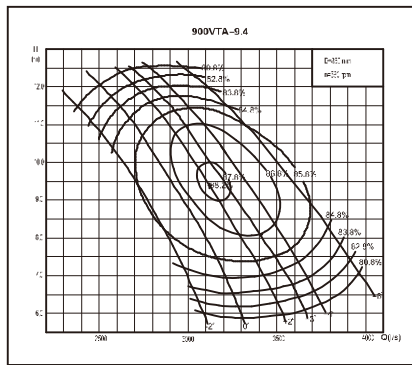
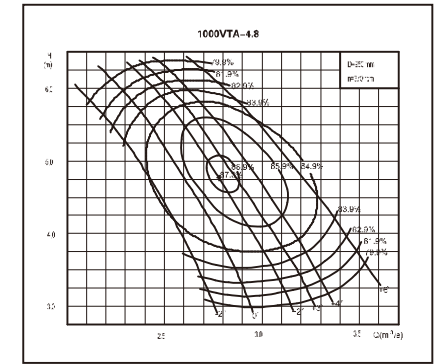
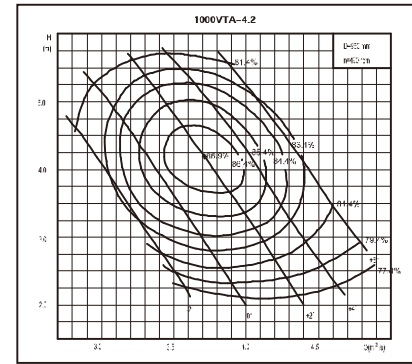
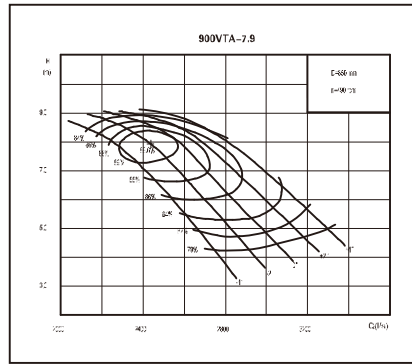
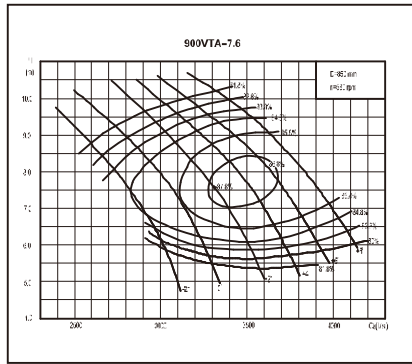

VTA,VTG Pump Curves

VTA,VTG Pump Curves

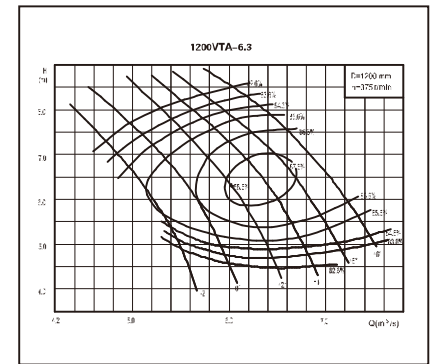
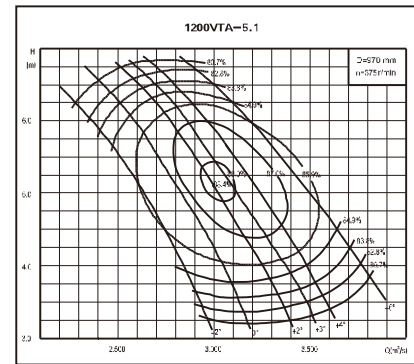
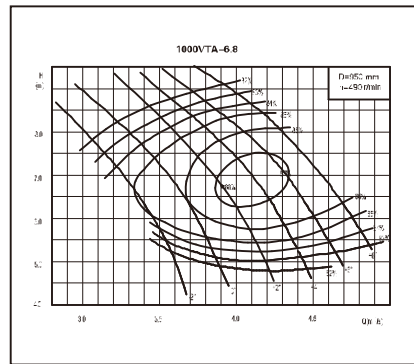
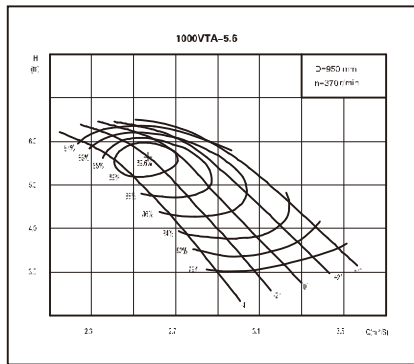
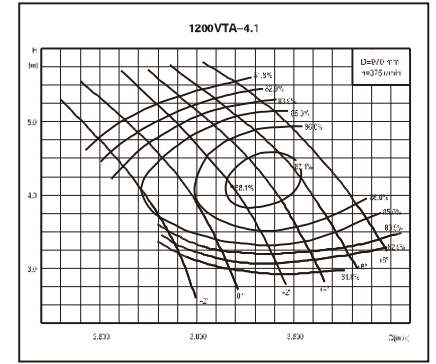
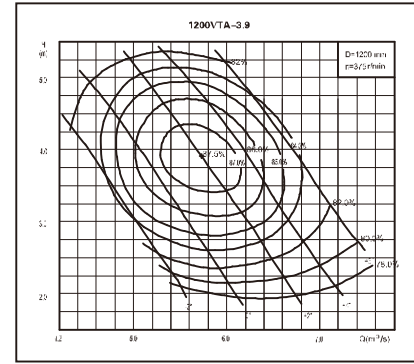
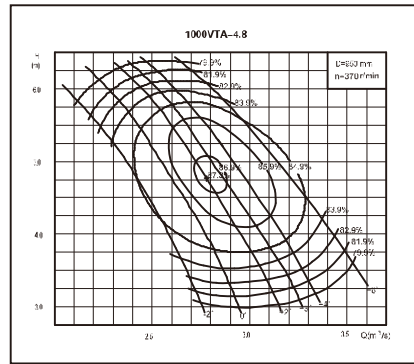
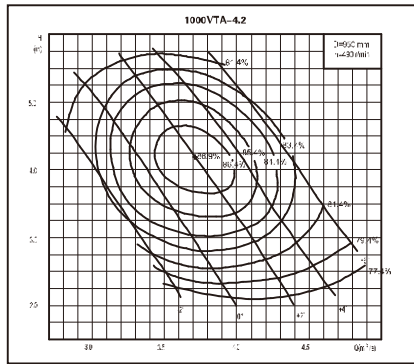
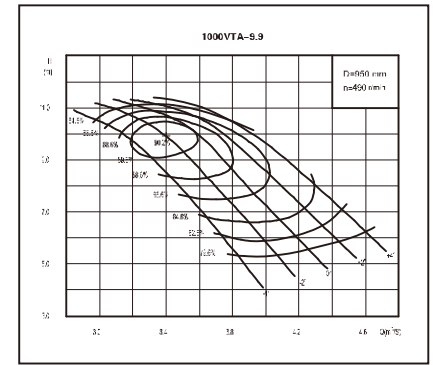
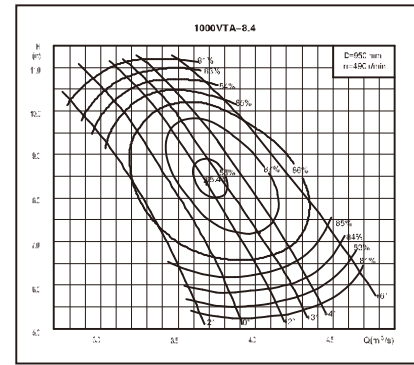
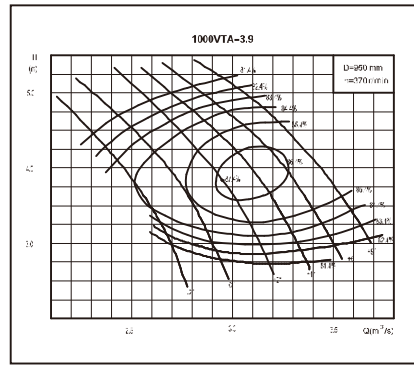
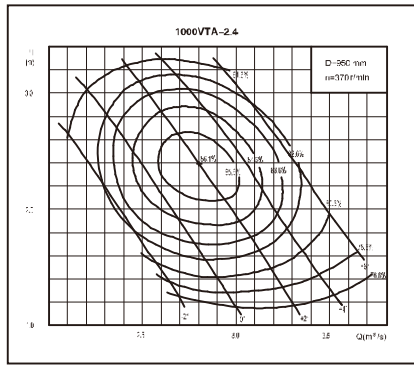

VTA,VTG Pump Curves

VTA,VTG Pump Curves

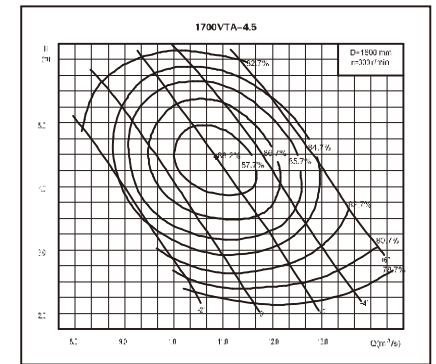
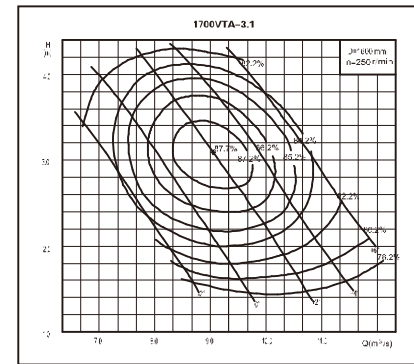
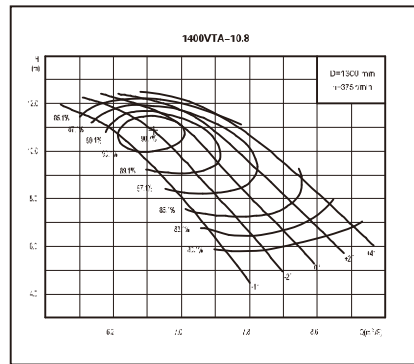
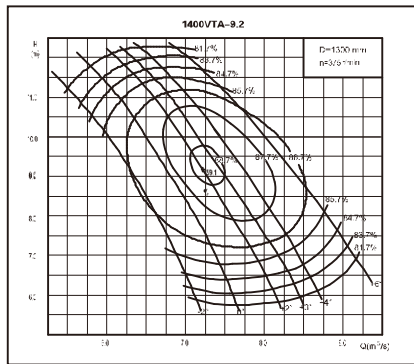
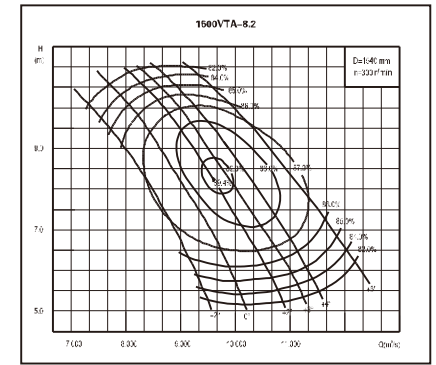
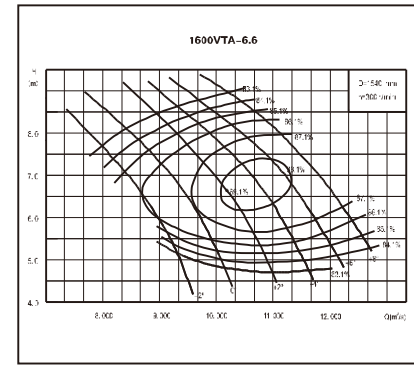
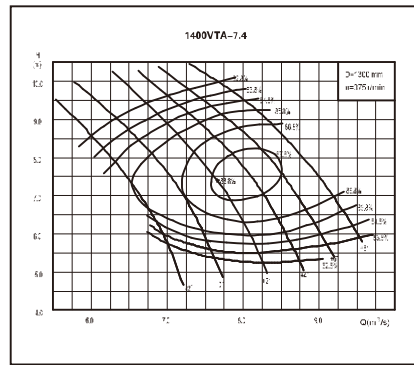
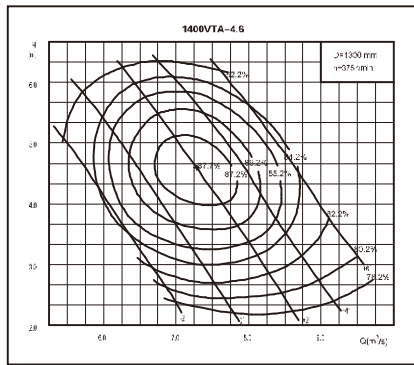
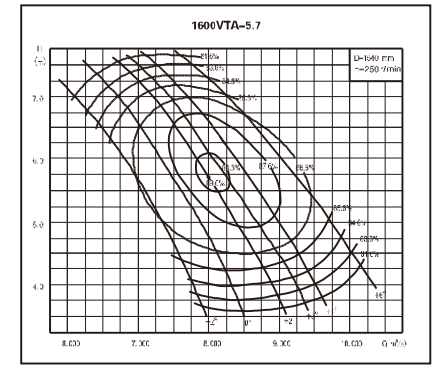
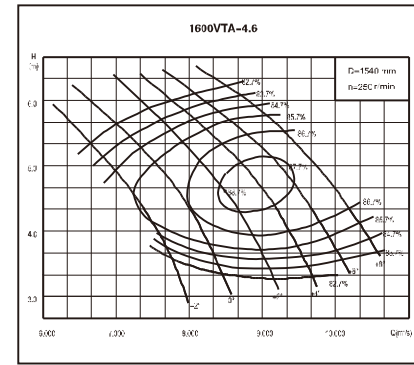
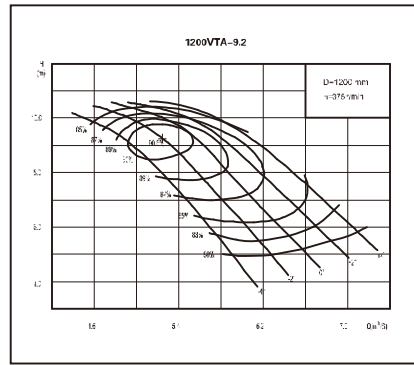
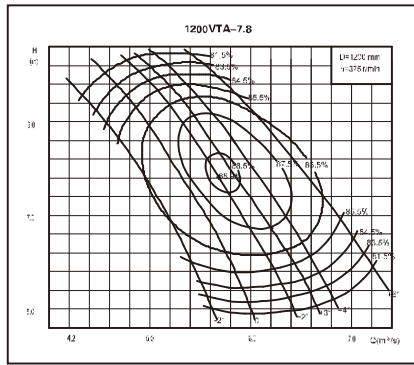

VTA,VTG Pump Curves

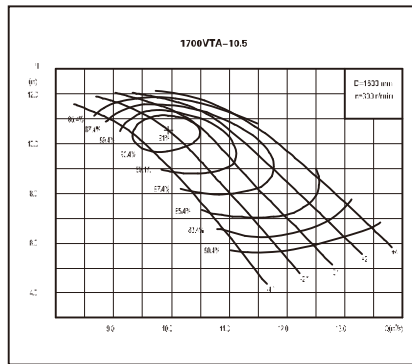
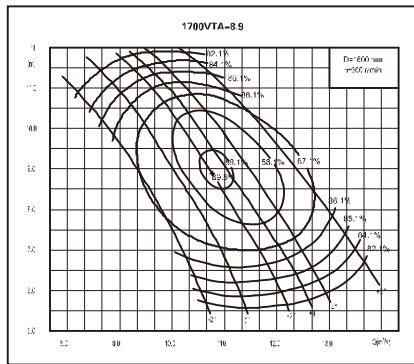
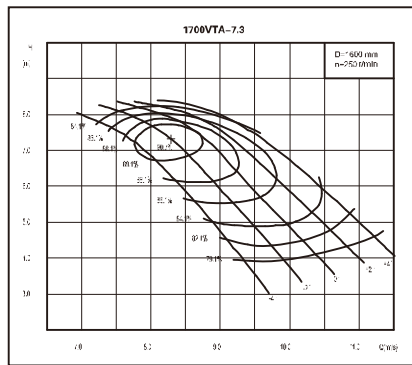
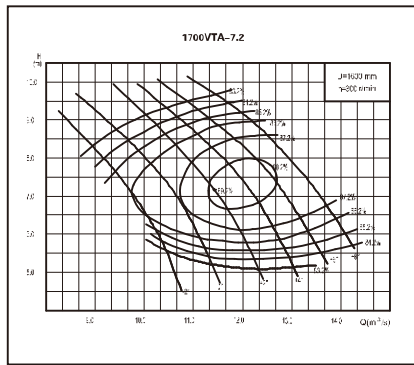
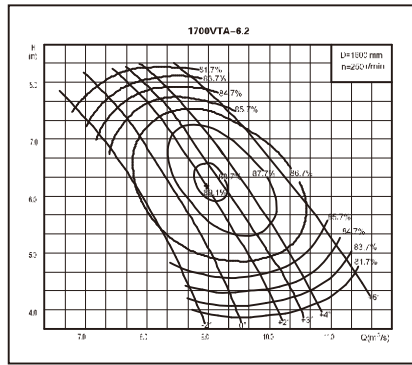
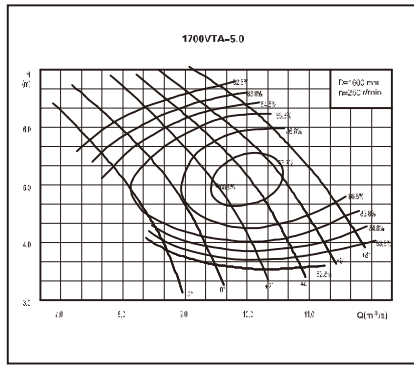

Oil Lubricated Thrust Bearing Assembling Sets

When the VTP designed driven by VSS motor, the pump's thrust will be loaded by the thrust bearing on the top of the pump or loaded by the top thrust bearing of the VSS motor.

CNP can supply two kinds of different thrust bearing assembly sets as following, design for the pumps with lower and higher thrust.

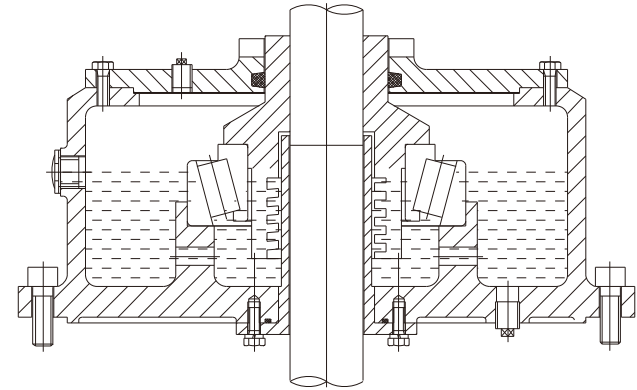

Standard thrust bearing assembly set

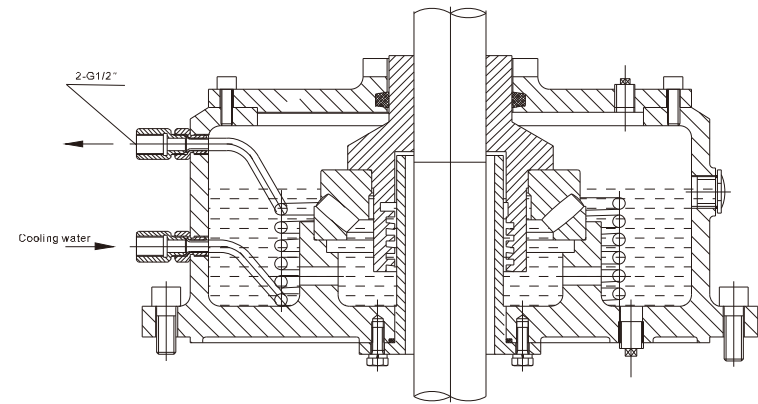

Water cooling heavy duty thrust bearing assembly set

