



SZ

50Hz

Fluorin Plastic Centrifugal Pump



Nanfang Pump Industry Co.,Ltd.

CNP Headquarter

Address: Renhe Town, Hangzhou, China

Post code: 311107

Tel: +86 571 86051667,86390516,86390517

Fax: +86 571 86051696

E-mail: info@nanfang-pump.com

<http://www.cnppump.com>

E150306
309010100025
subject to amendments



Company Profile



Founded in 1991, Nanfang Pump Industry Co., Ltd. (hereinafter referred to as CNP) has been listed on the Shenzhen Stock Exchange on 9th December 2010; Stock name: CNP; Stock code: 300145.

As the first enterprise specializing in the research and large-scale production of stainless steel stamping welded centrifugal pump in China, CNP is currently the professional manufacturer with the highest volume of production and marketing in that industry. It ranks first in the country in terms of product scope, sales volume, and production quality. The company has set up a complete network of marketing services to meet the requirements of overseas markets as well as domestic needs. The products have seen a wide range of application in the area of pressurization, industry, living water, cycling of air-conditioning water, heat supply, fire extinguishing system, pumping of underground water, treatment of sewage and waste water, chemical industry and desalination of sea water etc.

CNP has now entered into the fast track of development and has taken a major step forward in forging China Strong Pump Enterprise and World's famous brand in the Pump Industry. In order to better meet the client's needs and requirements for expansion, it has set up a wide network of selling and service, as well as offices and service centers in major cities in China, which are aimed at providing timely and effective services for our clients. Meanwhile, our company has successfully penetrated into the world market by forging a good business relationship with more than 50 countries and regions in the Europe, Northern American, and Southeast Asia etc.

Content

General Data

Definition of Model	3
Structure feature	3
Typical application	3
Operation conditions	3
Motor	3
Curve notes	3
Performance curve	3
Installation conditions	3

Technical Data

Performance scope	4
Performance table	4
Sectional drawing	5
Part list	5
SZ25/SZ40/SZ50	6
SZ65	7
SZ80	8
Pump dimensions	9
F46,F26 Corrosion resistance table	10

● Definition of Model

SZ50-32-160

SZ 50 - 32 - 160

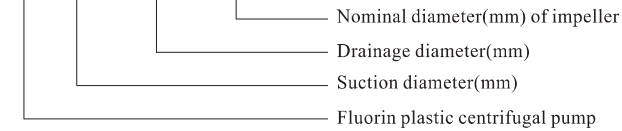

● Structure feature

- SZ pump has one impeller, axial suction and radical discharge.
- Simple structure, shaft is directly connected with impeller.
- Easy for pipe works, inlet and outlet are connected by standard flanges.
- Wet parts are made of F26.F46, accessories are made of cast iron(HT200).

● Typical application

- Any concentration of acid alkali, salty solution, strong oxidants, organic solvent etc. Strongly corrosive medium.
- Petrol, chemical, pesticide, acid cleaning, dying, paper making, galvanization, etc.

● Operation conditions

- Thin medium not containing grain or fiber.
- Medium temperature: -20℃~120℃
- Medium density: Max $1.35 \times 10^3 \text{kg/m}^3$
- Ambient temperature: Max+40℃
- Altitude: Max 1000m
- Pressure: Max 10bar

● Motor

- TEFC motor, 2 pole
- Protection class: IP 55
- Insulation level: CLASS F
- Standard voltage: 50Hz, 3 × 380V

● Curve conditions

- Curve tolerance in conformity to ISO9906:2012 Grade 3B.
- All curves are based on the measured value of constant motor speed 2900rpm, 50Hz, 3 × 380V.
- The measurements were made with airless water at temperature of 20℃. The curves apply to a kinematic viscosity of $1 \text{mm}^2/\text{s}$ (1 cst).
- It is suggested to operate the pump in the scope of the bold curve, to prevent motor from overload.
- When pumping liquids with a density higher than that of the operation conditions, use motors with correspondingly higher outputs.

● Performance curve

- Q/H: means the curve of the flow and head at the nominal rotating speed.
- Power curve: P2 means the pump input power, if the medium density is $1 \times 10^3 \text{kg/m}^3$.
- Efficient curve: Eta means the pump efficient.

● Installation conditions

- When installation, please make sure the pump would not be effected by the pipeline force when pump operation.
- The pump should be strongly fixed on the horizontal base.
- In order to make motor work well, pump should be installed on the frozen-free and ventilate place.
- The electric protection devices should protect pump from being damaged by phase lack, unstable voltage, electric leakage, overload.

● Performance scope

SZ 50Hz 2900rpm

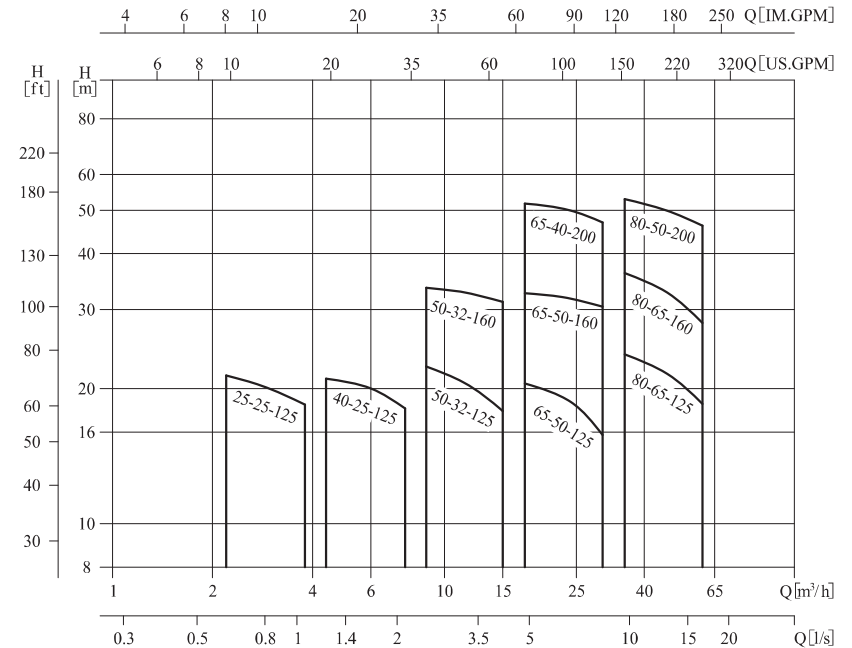

● Performance table

Model	Nominal flow [m³/h]	Nominal head [m]	Flow range [m³/h]	Max bar [bar]	Power [kW]	Max efficiency [%]
SZ25-25-125	3.2	20	2.2~3.8	2.1	1.1	28
SZ40-25-125	6.3	20	4.4~7.6	2.1	1.5	41
SZ50-32-125	12.5	20	8.8~15	2.3	3	44
SZ50-32-160	12.5	32	8.8~15	3.3	4	51
SZ65-50-125	25	20	17.5~30	2	4	55
SZ65-50-160	25	32	17.5~30	3.3	5.5	60
SZ65-40-200	25	50	17.5~30	5.1	11	55
SZ80-65-125	50	20	35~60	2.6	7.5	62
SZ80-65-160	50	32	35~60	3.6	11	62
SZ80-50-200	50	50	35~60	5.4	18.5	63

Sectional drawing

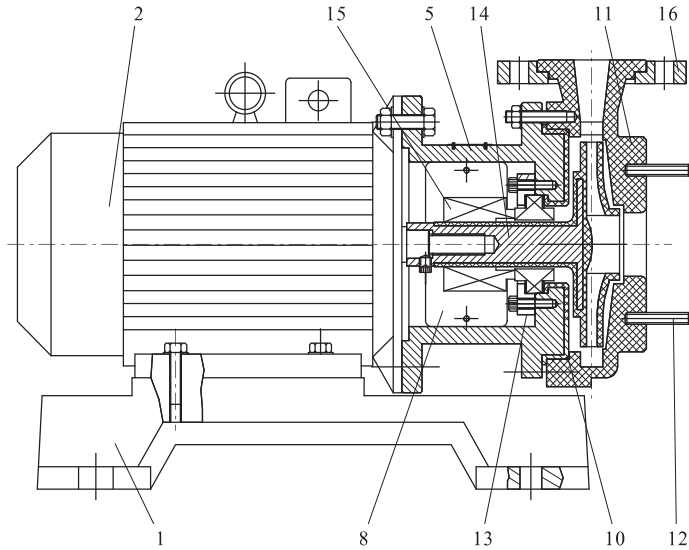

Part list

No.	Name	Material	Code/AISI/ASTM
1	Base	HT200	ASTM25B
2	Motor		
5	Injection moulding pump head	HT200+F26(F46)	ASTM25B+F26(F46)
8	Guard	Stainless Steel OCr18Ni9	AISI304
10	O ring	FPM	
11	Casing	F26(F46)	
12	Double end studs	Stainless Steel OCr18Ni9	AISI304
13	Seal cover	HT200	ASTM25B
14	Impeller	Steel+F26(F46)	ASTMA570+F26(F46)
15	Mechanical seal	Silicon Carbide/Silicon Carbide	
16	Outlet flange	HT200	ASTM25B

Performance curve SZ25 SZ40 SZ50

50Hz 2900rpm

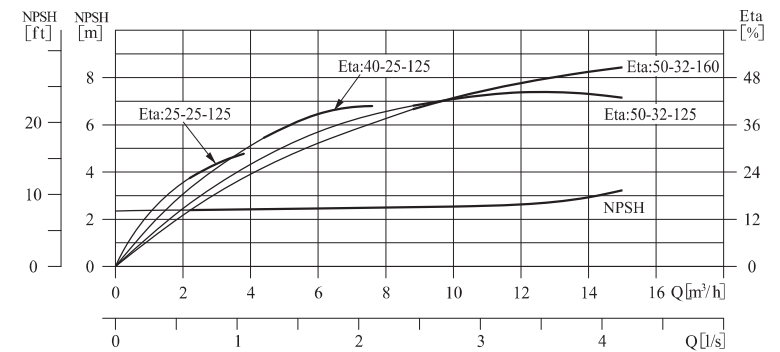
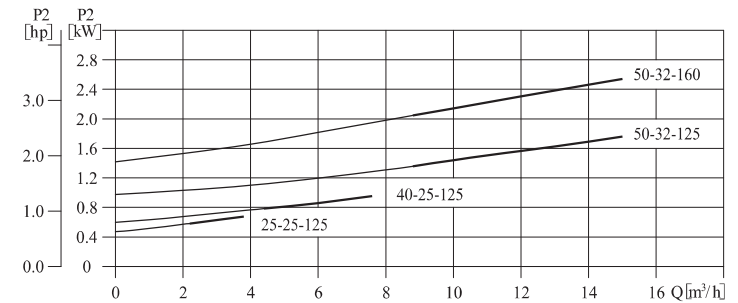
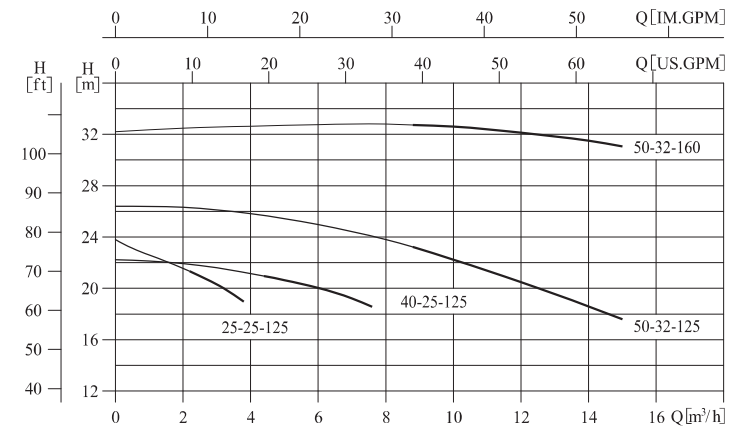

● Performance curve SZ65

50Hz 2900rpm

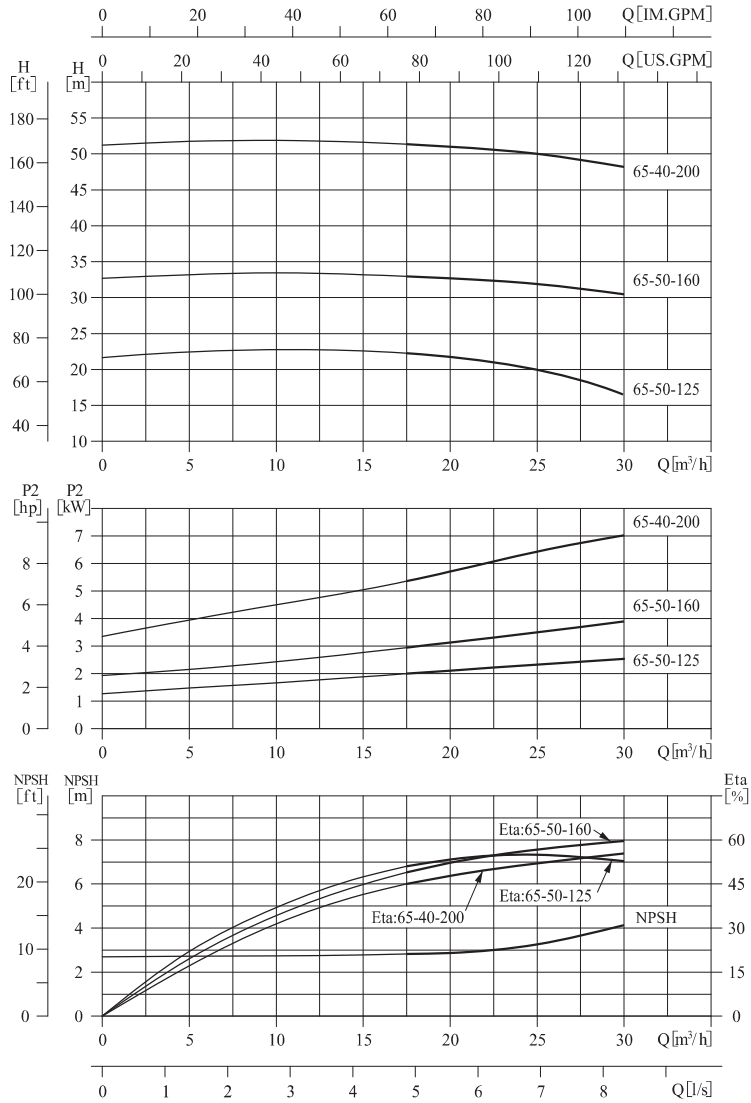

● Performance curve SZ80

50Hz 2900rpm

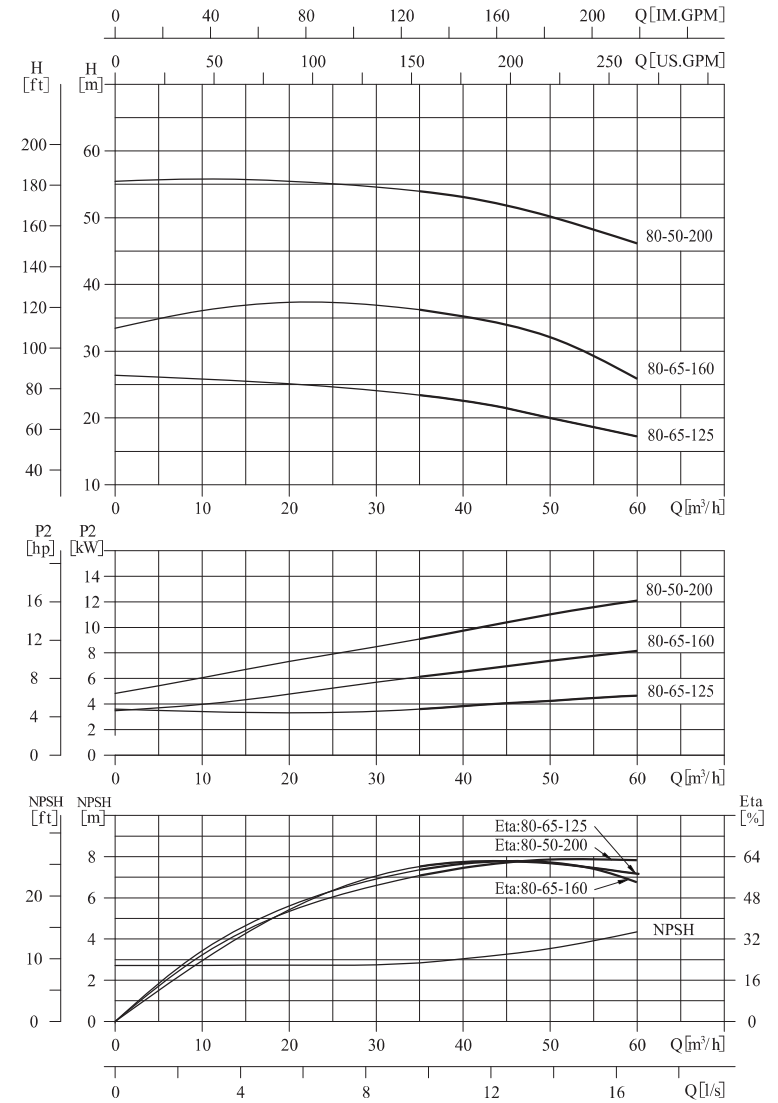

● Pump dimensions

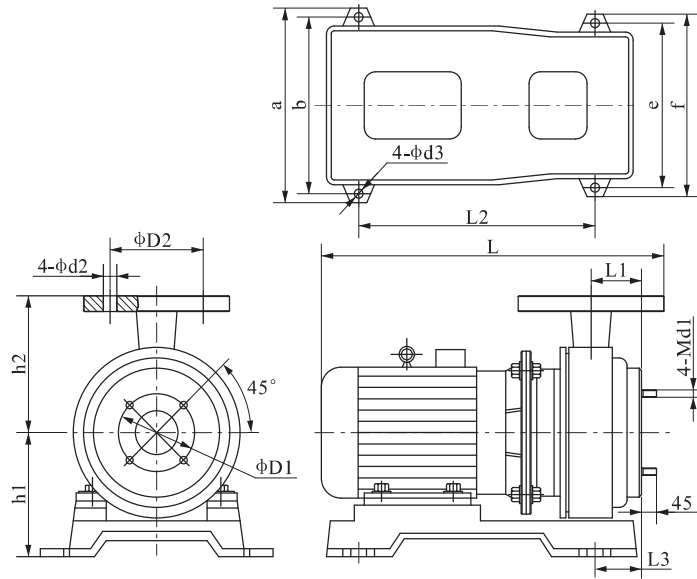

● Size and weight

Model	Size (mm)																Weight (kg)	
	L	L1	L2	L3	D1	Inlet flange	d1	h1	h2	D2	outlet flange	d2	a	b	d3	e		f
SZ25-25-125	457	37	300	64	75	DN25/PN6	10	164	120	100	DN32/PN10	14	265	230	15	230	265	45
SZ40-25-125	461	37	300	72	100	DN40/PN6	10	165	120	100		14	265	230	15	230	265	48
SZ50-32-125	531	43	370	79	125	DN50/PN10	14	175	140	100	14	275	235	17	235	275	74	
SZ50-32-160	553	53	370	103	125		14	191	159	100	14	315	270	17	270	315	78	
SZ65-50-125	563	50	370	95	145	DN50/PN10	14	175	147	125	18	315	270	17	270	315	79	
SZ65-50-160	618	51	400	88	145		14	219	165	125	18	370	330	17	290	335	113	
SZ65-40-200	727	55	440	96	145	DN40/PN10	18	425	380	19	320	365	181					
SZ80-65-125	631	52	400	88	160	DN65/PN10	14	219	165	145	18	370	330	17	290	335	123	
SZ80-65-160	750	57	440	97	160		14	255	186	145	18	425	380	19	320	365	183	
SZ80-50-200	797	57	440	110	160	DN50/PN10	18	425	380	19	320	365	205					

● F46, F26 Corrosion resistance table

Medium	F46	F26	Medium	F46	F26	Medium	F46	F26
Acetic acid; Benzene acid	✓	✓	Sulfuric Acid +20% Smoke sulfate	✓/80°C	—	Titanium tetrachloride; zinc chloride	✓	✓
Arsenate; Boric acid	✓	✓	Smoke sulfate	✓	×	Ferric Trichloride, carbon tetrachloride	✓	✓
Carbonate	✓	✓/20°C	sulfurous acid	✓	✓	Salt solution; seawater	✓	✓
Fluoride acid	✓	—	Ammonium hydroxide, potassium hydroxide	✓	✓	Alum (slurry); black liquor (slurry)	×	—
Hypochlorite; Wet chlorine	✓	✓	Sodium hydroxide <20%	✓	✓	Blue alum; NaHSO ₃	✓	✓
Chromic Acid	✓	✓/50°C	Sodium hydroxide <80%	✓	×	Sodium bicarbonate; soda	✓	✓
citric acid	✓	✓/120°C	Calcium hydroxide	✓	✓	Sodium hypochlorite	✓	✓/20%
Toluene-acid	✓	✓/65°C	Acetic acid salt solution	✓	✓	Sodium chlorate; calcium chloride	✓	✓
Formic acid	✓	✓	Ammonium nitrate; barium nitrate	✓	✓	Chromium sodium	✓	—
Glycolic acid	—	✓/20°C	Sodium nitrate; copper nitrate	✓	✓	Al acetic	✓	✓
hydrochloric acid	✓/65°C	✓/37%	Iron nitrate	✓	✓	Bromine	✓	✓/20°C
hydrofluoric acid; Fluorosilicic acid	✓	✓	Nitrate lead; silver nitrate	✓	—	Glycerol	✓	✓
Hydrogen Peroxide; lactic acid	✓	✓/20°C	Aluminum sulfate, ammonium sulfate	✓	✓	Pyridine	✓	×
Maleic acid; malic acid	✓	✓	ammonium sulfate + Sulfuric Acid	✓	✓	acetic (acid) anhydride	✓	✓/20°C
Mixed acid	✓	—	Barium sulfate; sodium sulfate	✓	✓	Aniline dye; hydrochloride aniline	✓	—
Oleic acid	✓	✓	Copper sulfate	✓	✓	Methane, ethane, propane	✓	✓
Oxalate acid	✓	✓/50°C	Copper sulfate +10% Sulfuric Acid	✓	—	Nitrobenzene	✓	✓/20°C
Picric acid, stearic acid	✓	✓/20°C	Ferrum sulfate +10% Sulfuric Acid	✓	—	Tar and ammonia	✓	—
Tartrate; Tannin	✓	✓	Magnesium sulfate; zinc sulfate	✓	✓	Toluene; SO ₃	✓	✓
Nitrate 5% to 10%	✓	✓/50°C	Ammonium; sodium	✓	✓	Glycol; ethylene oxide	✓	✓
Nitric Acid <50%	✓	✓	Chloride; barium chloride	✓	✓	Two-acetone; dichloro-ethanol	✓	✓/20°C
Concentrated nitric acid	✓	×	Calcium chloride	✓	✓	Diethylene dioxide; vinyl Trichloride	✓	✓
Nitric Acid +3.5% hydrofluoric acid	✓	—	Aluminum Trichloride	✓	✓/20%	Formaldehyde	✓	✓/50°C
Phosphoric Acid	✓	✓	Potassium chloride	✓	✓/65°C	Freon	×	—
Phosphoric Acid +2% Sulfuric acid +1% hydrofluoric acid	✓	—	Sodium chloride; tin chloride	✓	✓	CS ₂	✓	✓/20°C
sulfuric acid <10%	✓	✓	Silver chloride, magnesium chloride	✓	✓	Molten sulfur	✓	✓
Sulfuric acid 10% to 75%	✓	✓/65°C	Nickel Chloride	✓	✓			
Sulfuric acid 75% to 98%	✓/80°C	✓/50°C	Sulphur dichloride	✓	✓/20°C			

Note: 1. ✓/20°C means the material can be used in the medium that temperature is below 20°C. ✓ means workable, × means doesn't work. — means not known.
2. ✓/20% means the material can be used in the 20% medium.

MEMO

A series of horizontal dashed lines for writing.

MEMO

A series of horizontal dashed lines for writing.

