

**Receiver**
**From**

 Society  
 Reference  
 Address  
 Phone  
 Fax  
 E-mail

**Item n° :**

60176796

**Model :**

FKC 80 15.4 T5 400D

**Pump data**

Type of impeller :	Single channel impeller
Pump outlet :	DN 80
Pump inlet :	DN 80
Flange standard :	EN 1092-1 / PN 16
Free passage :	80 mm
Fluid Temperature :	32 °F / 104 °F*
* For higher temperatures please contact our sales network	
pH	6,5 - 12
Kinematic viscosity :	1/0764E-5 ft <sup>2</sup> /s
Max Flow :	413/87 US g.p.m.
Max. Head :	7/861 m
Max. Hy draulic efficiency :	57 %

**Approvals**

Approvals :	12050-1
ATEX :	NO

**INSTALLATION**

Max. Ambient temperature :	104 °F
Max. installation depth :	20 m
Type of installation :	
<u>Wet - Pump only</u>	

**Materials**

Handle	Stainless Steel (AISI 304)
Electric cable	07RN8-F
Screws	Stainless Steel (AISI 304)
OR	NBR
Mechanical seal pump side	SiC/SiC
Mechanical seal motor side	SiC/Carbon
Motor shaft	AISI 420
Pump body / motor	Cast iron (EN GJL 200)
Impeller	Cast iron (EN GJL 250)
Wear ring	Cast iron (EN GJL 150)
Coating	Acrylic Two-component 50µm

**Motor data**

Number of poles :	4
Max. Input power P1 :	1/72 kW
<b>Nominal power P2 :</b>	1/5 kW
Rated voltage :	3~ 400 V (+6% / -10%) 50 Hz
Nominal current :	3/5 A
Starting current (DOL / YD) :	11/4 A / —
Starting :	Directly
Rated speed :	1450 rpm
Efficiency :	87/2 %
Number of starts :	20 /h
Degree of protection :	IP 68
Insulation class :	F 302 °F
Standard cable type :	10mt 4G1.5+3x1
Water-in-oil sensor :	NO
Motor protection :	Thermal switch

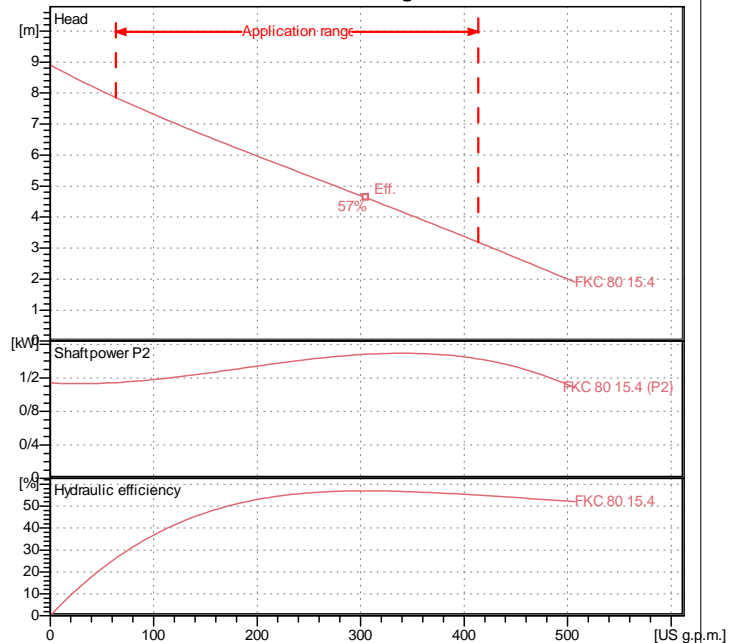
**Curve tolerance according to ISO 9906**

**Fluid data**

Fluid :	Water, pure	Fluid Temperature :	68 °F
Density :	62/322 lb/ft <sup>3</sup>	Kinematic viscosity :	1/0818E-5 ft <sup>2</sup> /s

**Requested data**

Flow :	0 US g.p.m.
Head :	0 m

**Real duty point**

Flow :	
Head :	

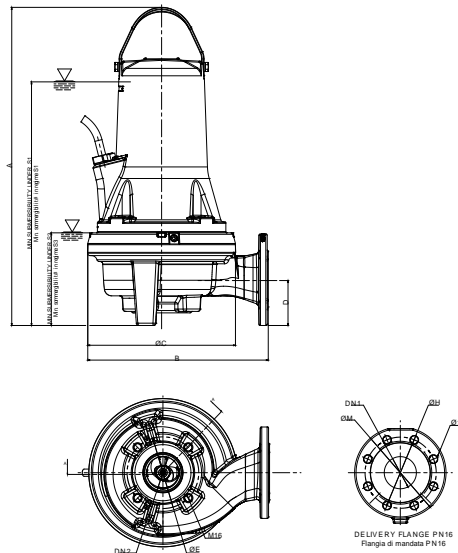

<b>Pump weight :</b>	On demand kg	<b>Accessory weight :</b>	0 kg
----------------------	--------------	---------------------------	------

**Dimensions in mm**

?18	8x?18	DN1	80		
?C	355	DN2	100		
?E	180	S1	514		
?H	160	S3	208		
?M	200				
A	665				
B	435				
D	100				