

**Receiver**
**From**

 Society  
 Reference  
 Address  
 Phone  
 Fax  
 E-mail

**Item n° :**  
 60171444  
**Model :**  
 FKV 80 15.4 T5 400D

**Pump data**

 Type of impeller : §Vortex  
 Pump outlet : DN 80  
 Pump inlet : DN 80  
 Flange standard : EN 1092-1 / PN 16  
 Free passage : 80 mm  
 Fluid Temperature : 32 °F / 104 °F\*

\* For higher temperatures please contact our sales network

 pH : 6,5 - 12  
 Kinematic viscosity : 1/0764E-5 ft<sup>2</sup>/s  
 Max Flow : 308/2 US g.p.m.  
 Max. Head : 9/329 m  
 Max. Hydraulic efficiency : 41/6 %

**Approvals**

 Approvals : 12050-1  
 ATEX : NO

**INSTALLATION**

 Max. Ambient temperature : 104 °F  
 Max. installation depth : 20 m  
 Type of installation :  
Wet - Pump only
**Materials**

 Handle : Stainless Steel (AISI 304)  
 Electric cable : 07RN8-F  
 Screws : Stainless Steel (AISI 304)  
 OR : NBR  
 Mechanical seal pump side : SiC/SiC  
 Mechanical seal motor side : SiC/Carbon  
 Motor shaft : AISI 420  
 Pump body / motor : Cast iron (EN GJL 200)  
 Impeller : Cast iron (EN GJL 250)  
 Coating : Acrylic Two-component 50µm

**Motor data**

 Number of poles : 4  
 Max. Input power P1 : 1/72 kW  
**Nominal power P2 :** 1/5 kW  
 Rated voltage : 3~ 400 V (+6% / -10%) 50 Hz  
 Nominal current : 3/8 A  
 Starting current (DOL / YD) : 11/4 A / —  
 Starting : Directly  
 Rated speed : 1450 rpm  
 Efficiency : 87/2 %  
 Number of starts : 20 /h  
 Degree of protection : IP 68  
 Insulation class : F 302 °F  
 Standard cable type : 10mt 4G1.5+3x1  
 Water-in-oil sensor : NO  
 Motor protection : Thermal switch

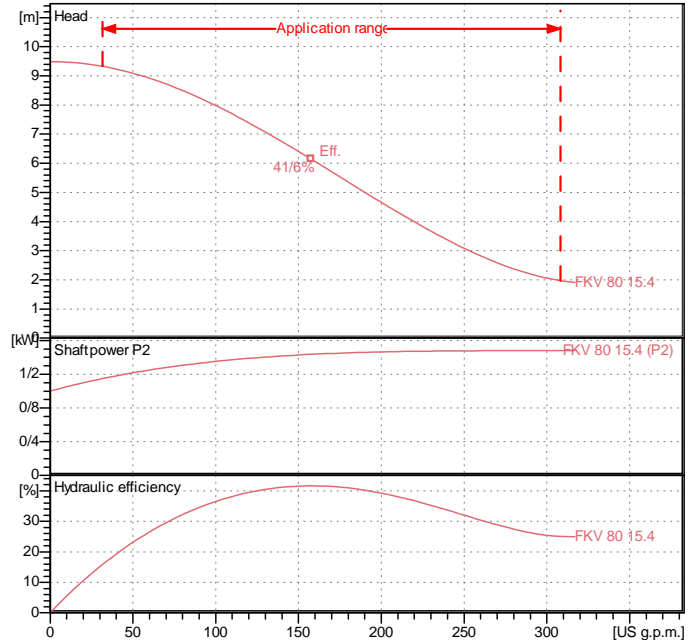
**Curve tolerance according to ISO 9906**

**Fluid data**

 Fluid : Water, pure Fluid Temperature : 68 °F  
 Density : 62/322 lb/ft<sup>3</sup> Kinematic viscosity : 1/0818E-5 ft<sup>2</sup>/s

**Requested data**

 Flow : 0 US g.p.m.  
 Head : 0 m

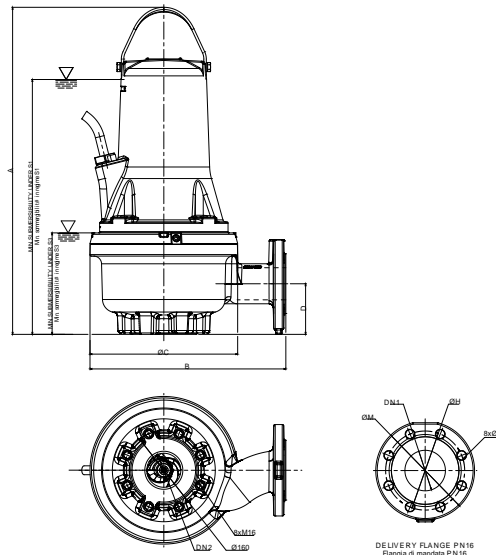
**Real duty point**

 Flow :  
 Head :

**Pump weight :** 103 kg

**Accessory weight :** 0 kg

**Dimensions in mm**

∅C	336	S1	540		
∅H	160	S3	230		
∅M	200				
A	686				
B	409				
D	109				
DN1	80				
DN2	80				