

Receiver
From

 Society
 Reference
 Address
 Phone
 Fax
 E-mail

Item n° :
 60171448
Model :
 FKV 100 55.4 T5 400Y/D

Pump data

 Type of impeller : §Vortex
 Pump outlet : DN 100
 Pump inlet : DN 100
 Flange standard : EN 1092-1 / PN 16
 Free passage : 100 mm
 Fluid Temperature : 32 °F / 104 °F*
 * For higher temperatures please contact our sales network
 pH 6,5 - 12
 Kinematic viscosity : 1/0764E-5 ft²/s
 Max Flow : 570/61 US g.p.m.
 Max. Head : 15/71 m
 Max. Hydraulic efficiency : 42 %

Approvals

 Approvals : 12050-1
 ATEX : NO

INSTALLATION

 Max. Ambient temperature : 104 °F
 Max. installation depth : 20 m
 Type of installation :
Wet - Pump only..
Materials

 Handle Stainless Steel (AISI 304)
 Electric cable 07RN8-F
 Screws Stainless Steel (AISI 304)
 OR
 Mechanical seal pump side SiC/SiC
 Mechanical seal motor side SiC/Carbon
 Seal ring HNBR
 Motor shaft AISI 420
 Pump body / motor Cast iron (EN GJL 200)
 Impeller Cast iron (EN GJL 250)
 Coating Acrylic Two-component 50µm

Motor data

 Number of poles : 4
 Max. Input power P1 : 6/06 kW
 Nominal power P2 : 5/5 kW
 Rated voltage : 3~ 400 V (+6% / -10%) 50 Hz
 Nominal current : 11/3 A
 Starting current (DOL / YD) : 50/3 A / —
 Starting : Star-delta
 Rated speed : 1450 rpm
 Efficiency : 90/8 %
 Number of starts : 20 /h
 Degree of protection : IP 68
 Insulation class : F 302 °F
 Standard cable type : 10mt 7G2.5+3x1
 Water-in-oil sensor : NO
 Motor protection : Thermal switch

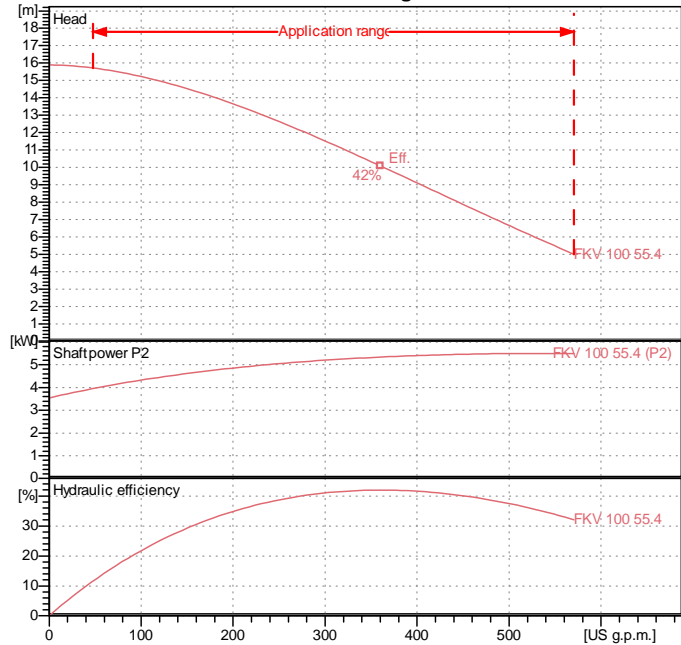
Curve tolerance according to ISO 9906

Fluid data

 Fluid : Water, pure Fluid Temperature : 68 °F
 Density : 62/322 lb/ft³ Kinematic viscosity : 1/0818E-5 ft²/s

Requested data

 Flow : 0 US g.p.m.
 Head : 0 m

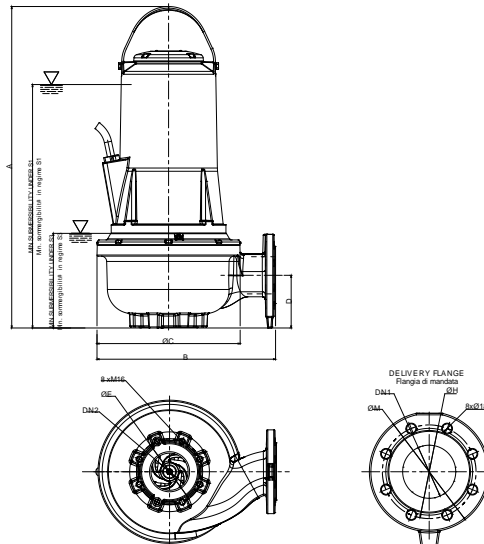
Real duty point

 Flow :
 Head :

Pump weight : 205 kg **Accessory weight :** 0 kg

Dimensions in mm

?C	390	DN2	100		
?E	180	S1	670		
?H	180	S3	260		
?M	230				
A	883				
B	490				
D	145				
DN1	100				