

Receiver
From

 Society
 Reference
 Address
 Phone
 Fax
 E-mail

Item n° :

103010560

Model :

GRINDER 1800 T

Pump data

Pressure rating :

Min. fluid temperature : 32 °F

Max. fluid temperature : 131 °F

Max. Ambient temperature : 104 °F

Requested data

Flow : 0 US g.p.m.

Head : 0 m

Fluid : Water, pure

Fluid Temperature : 68 °F

 Density : 62/322 lb/ft³

 Kinematic viscosity : 1/0818E-5 ft²/s

Vapor pressure : 2/337 kPa

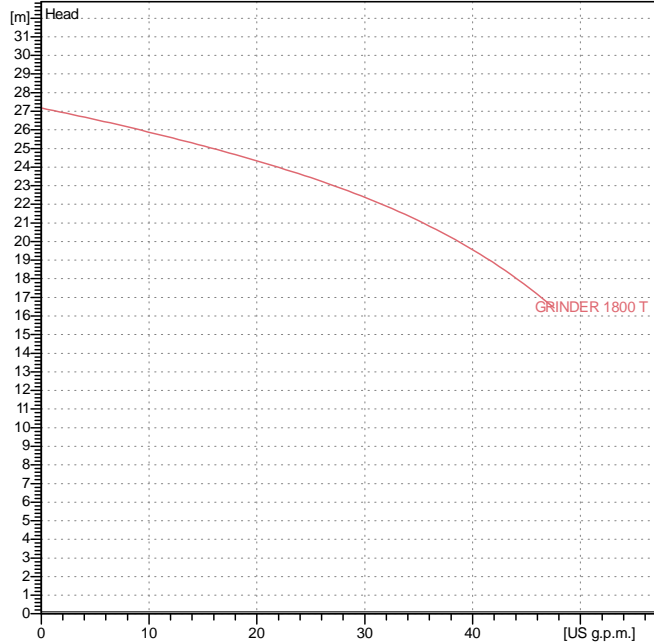
Curve tolerance according to ISO 9906

Hydraulic data (duty point)

Flow :

Head :

Materials

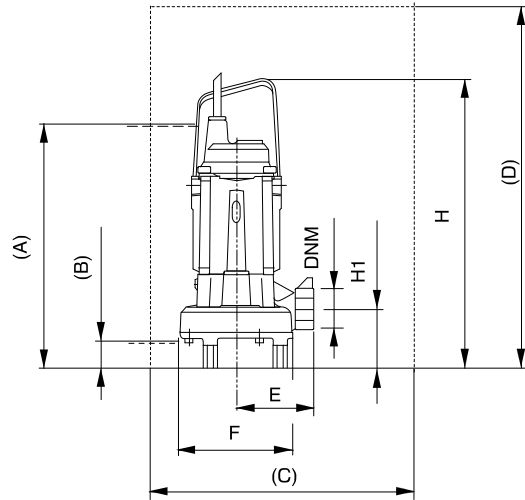
Pump body	Cast iron 200 UNI ISO 185
Impeller	Cast iron 200 UNI ISO 185
Motor shaft	AISI 416 X12 CrS 13 UNI 6900/71
Pump body OR ring	Viton
Suction cover	Cast iron 200 UNI ISO 185
Mechanical seal	Silicon carbide
Fixed grinder section	AISI 440

Motor data
Weight : 43/8 kg

Motor brand :	DAB	
Nominal power P2 :	1/5 kW	
Rated voltage :	3~ 400 V	50 Hz
Nominal current :	3/8 A	
Number of poles :	2	
Rated speed :	2800 rpm	
Degree of protection :	IP 68	

Dimensions in mm

Dimension	Value	Dimension	Value
A	500	H	549
B	50	H1	109
C	500 x 500 min		
D	600 min		
DNM	2" G		
E	150		
F ?	219		

Pump connection

 Suction side : /
 Discharge side : 2" G / --