

Receiver
From

 Society
 Reference
 Address
 Phone
 Fax
 E-mail

Item n° :

60141588

Model :

GRINDER 1600 T-NA

Pump data

 Free passage : 5 mm
 Pressure rating :
 Min. fluid temperature : 32 °F
 Max. fluid temperature : 104 °F
 Max. Ambient temperature :

Requested data

 Flow : 0 US g.p.m.
 Head : 0 m
 Fluid : Water, pure
 Fluid Temperature : 68 °F
 Density : 62/322 lb/ft³
 Kinematic viscosity : 1/0818E-5 ft²/s
 Vapor pressure : 2/337 kPa

Hydraulic data (duty point)

 Flow :
 Head :

Materials

 Cover : Cast iron (EN GJL 200)
 Impeller : Cast iron (EN GJL 200)
 Pump body : Cast iron (EN GJL 200)
 Mechanical seal motor side : Carbon/Alumina
 Mechanical seal pump side : Carbon/Alumina
 Motor body : Cast iron (EN GJL 200)
 Grinder : Stainless Steel AISI 440C

Motor data

 Motor brand : DAB
 Nominal power P2 : 1/8 kW
 Rated speed : 2900 rpm
 Rated voltage : 3~ 400 V
 Nominal current : 5/8 A
 Degree of protection : IP 68

50 Hz

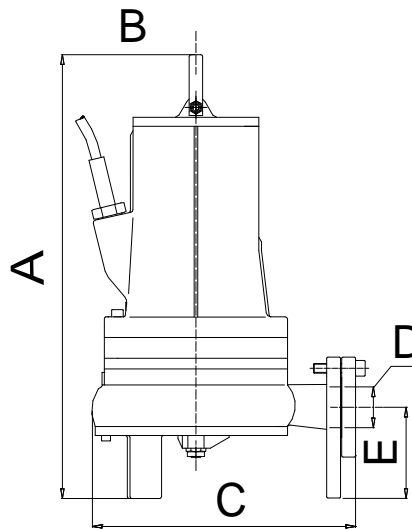
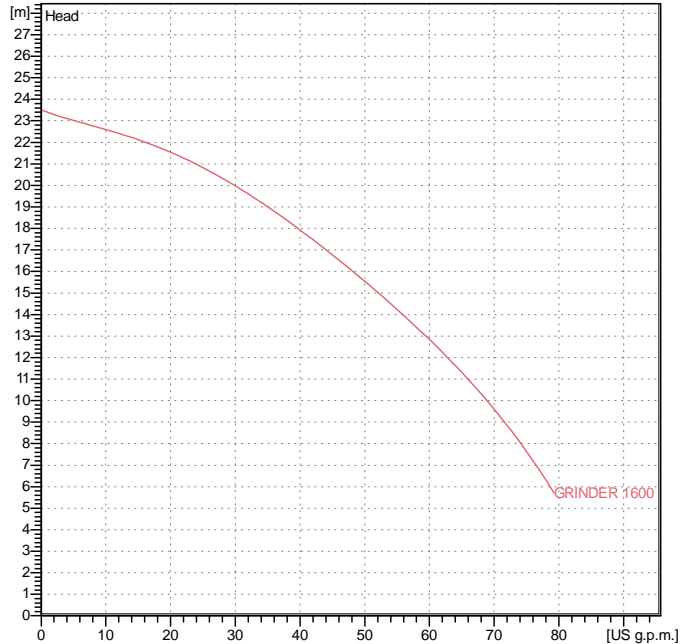
Curve tolerance according to ISO 9906

Weight : 40 kg

Dimensions in mm

Dimension	Value	Unit
A	445	mm
B	145	mm
C	270	mm
D	2" G	mm
E	110	mm

Pump connection

 Suction side : /
 Discharge side : 2" G / 10 bar (1000 KPa)